



Excellent Integrated System Limited

Stocking Distributor

Click to view price, real time Inventory, Delivery & Lifecycle Information:

[Molex Connector Corporation](#)
[0901192121](#)

For any questions, you can email us directly:
sales@integrated-circuit.com

10 9 8 7 6 5 4 3 2 1

SECTION X-X

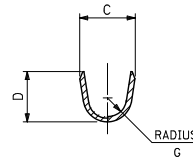
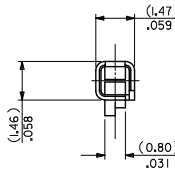

SECTION Z-Z
INSULATION BARREL

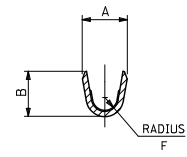

SECTION Y-Y
WIRE BARREL

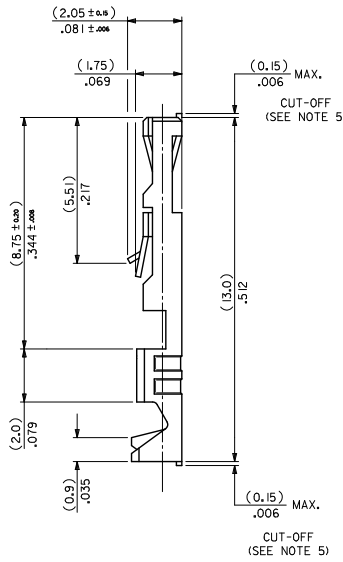
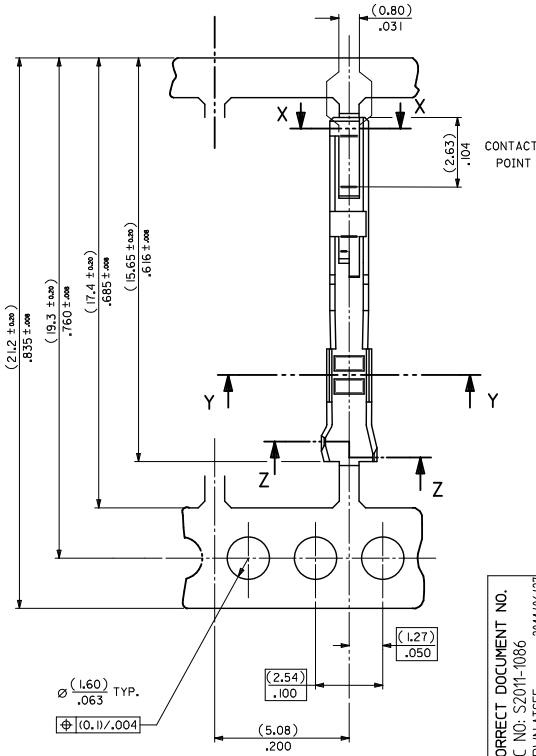

NOTES:

1. MATERIAL - PHOSPHOR BRONZE CDA 521 THICKNESS* (0.200)/.008 TENSILE STRENGTH* 655-760 N/mm² PLATING - SEE SHEET 2
2. FOR DIMENSIONS A, B, C, D, F & G SEE SHEET 2
3. FOR WIRE SIZE & INSULATION DIA SEE SHEET 2
4. THIS TERMINAL TO MATE WITH (0.635)/.025 SQUARE PIN
5. MAX BURR AFTER CUT-OFF (0.025)/.001

CORRECT DOCUMENT NO. EC NO. S2011-1086	2011/06/27	QUALITY SYMBOLS √=0	GENERAL TOLERANCES (UNLESS SPECIFIED)		DIMENSION STYLE MM ONLY		SCALE NTS	DESIGN UNITS METRIC	THIRD ANGLE PROJECTION
	2011/07/04		mm	INCH	DRAWN BY NPC	DATE 1987/08/27	TITLE C-GRID III FEMALE CRIMP TERMINAL		
DRW/AT/SEE	2011/07/04	DESCRIPTION	4 PLACES ± --- ± ---		CHECKED BY D. MORIARTY	DATE 2005/08/26	MATERIAL NO. MLONG		DATE 2011/07/04
CHKD/SKANG	2011/07/04	APPROVAL	3 PLACES ± --- ± .004		APPROVED BY	DATE	MOLEX INCORPORATED		DOCUMENT NO. SD-90119
2 PLACES ± 0.1 ± .008			1 PLACE ± 0.2 ± ---		ANGULAR ± .5 °		SEE TABLE		SHEET NO. 1 OF 2
1 PLACE ± 0.2 ± ---			DRAFT WHERE APPLICABLE MUST REMAIN WITHIN DIMENSIONS		THIS DRAWING CONTAINS INFORMATION THAT IS PROPRIETARY TO MOLEX INCORPORATED AND SHOULD NOT BE USED WITHOUT WRITTEN PERMISSION				

9 8 7 6 5 4 3 2 1

10 9 8 7 6 5 4 3 2 1

PART No	PLATING	REELING	WIRE SIZE (AWG)	INSULATION RANGE	CRIMP DIMENSIONS					
					WIRE BARREL			INSULATION BARREL		
					A ±(0.15) ±.006	B ±(0.15) ±.006	F ±(0.15) ±.006	C ±(0.15) ±.006	D ±(0.15) ±.006	G ±(0.15) ±.006
90119-0109	A	L.H FEED	22,24	(1.02-1.47) .040-.058	(1.70)	(1.70)	(0.51)	(2.10)	(1.90)	(0.70)
-0110	E				.067	.067	0.20	.083	.075	0.27
-0111	F									
-0112	D									
-0120	A		26,28	(0.76-1.22) .030-.048	(1.37)	(1.37)	(0.28)	(2.00)	(1.70)	(0.60)
-0121	E				.054	.054	0.11	.079	.067	0.24
-0122	F									
-0123	D									
-2109	A	LOOSE PIECE PARTS	22,24	(1.02-1.47) .040-.058	(1.70)	(1.70)	(0.51)	(2.10)	(1.90)	(0.70)
-2110	E				.067	.067	0.20	.083	.075	0.27
-2111	F									
-2112	D									
-2120	A		26,28	(0.76-1.22) .030-.048	(1.37)	(1.37)	(0.28)	(2.00)	(1.70)	(0.60)
-2121	E				.054	.054	0.11	.079	.067	0.24
-2122	F									
-2123	D									
90119-2123	D									

TYPE	PLATING
A	PRE-PLATED HOT DIP TIN (1.0 to 2.5 um)/.00004 TO .0001
E	(1.27 TO 1.78um)/.00005 TO .00007 NICKEL OVERALL. (0.38 TO 0.64um)/.000015 TO .000025 GOLD ON CONTACT AREA. (3.0 TO 5.0 um)/.00012 TO .0002 TIN ON TERMINATION AREA.
F	(1.27 TO 1.78um)/.00005 TO .00007 NICKEL OVERALL. (0.76 TO 0.10 um)/.00003 TO .00004 GOLD ON CONTACT AREA. (3.0 TO 5.0 um)/.00012 TO .0002 TIN ON TERMINATION AREA.
D	1.25µm MIN NICKEL OVERALL. 0.05µm TO 0.10µm GOLD FLASH ON CONTACT AREA 2.50µm MIN TIN ON CRIMP AREA

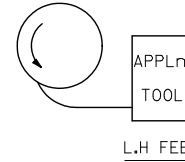

CORRECT DOCUMENT NO. EC NO: S2011-086 DRAWN BY: DRW:WATSEE CHKD:SKANG APPR:MLONG	QUALITY SYMBOLS ▽=0 ▽=0 ▽=0	GENERAL TOLERANCES (UNLESS SPECIFIED)		DIMENSION STYLE	SCALE	DESIGN UNITS	THIRD ANGLE PROJECTION	
		mm	INCH	MM ONLY	NTS	METRIC		
		4 PLACES ±.004	±.004	DRAWN BY: NPC	DATE: 1987/08/27	TITLE: C-GRID III FEMALE CRIMP TERMINAL		
		3 PLACES ±.004	±.004	CHECKED BY: D. MORIARTY	DATE: 2005/08/26	MOLEX INCORPORATED		
2 PLACES ±0.1	±.008	APPROVED BY: MLONG	DATE: 2011/07/04	MATERIAL NO. SEE TABLE	DOCUMENT NO. SD-90119	SHEET NO. 2 OF 2		
1 PLACE ±0.2	±.008	DRAFT WHERE APPLICABLE MUST REMAIN WITHIN DIMENSIONS		THIS DRAWING CONTAINS INFORMATION THAT IS PROPRIETARY TO MOLEX INCORPORATED AND SHOULD NOT BE USED WITHOUT WRITTEN PERMISSION				

9 8 7 6 5 4 3 2 1