

## Excellent Integrated System Limited

Stocking Distributor

Click to view price, real time Inventory, Delivery & Lifecycle Information:

[Amphenol RF](#)  
[31-10](#)

For any questions, you can email us directly:

[sales@integrated-circuit.com](mailto:sales@integrated-circuit.com)

# BNC 50 ohm Bulkhead Receptacles

Amphenol®

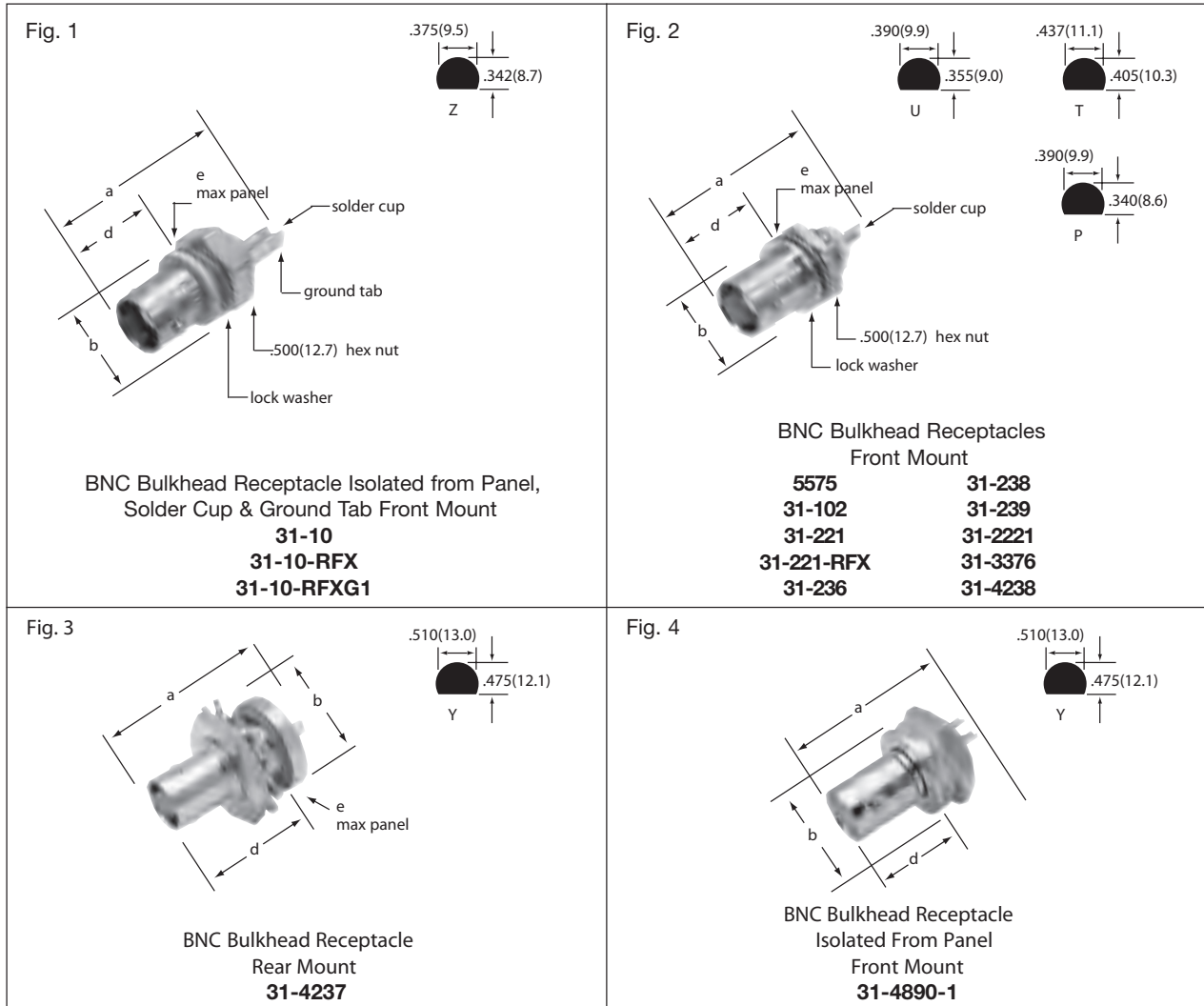

## BNC BULKHEAD RECEPTACLES

Description	Terminal Type	Dimensions, inches (mm)				Notes		Mtg. Hole	Military Number	Amphenol Number	Fig.
		a	b	d	e	Plt.	Ins.				
Front Mount, Isolated from Panel	Solder Cup	1.19(30.2)	.500(12.7)	.471(12.0)	.187(4.8)	P1	D22	Z	—	31-10*	1 ▲
	Solder Cup	1.18(30.0)	.500(12.7)	.471(12.0)	.125(3.2)	P1	D22	Z	—	31-10-RFX	1 ▲
Front Mount	Solder Cup	1.18(30.0)	.500(12.7)	.471(12.0)	.187(4.8)	P7	D22	Z	—	31-10-RFXG1	1 ▲
Front Mount	Solder Cup	1.06(27.0)	.500(12.7)	.484(12.3)	.125(3.2)	P1	D1	U	UG-1094/U	31-221*	2 ▲
		1.06(27.0)	.500(12.7)	.472(12.0)	.125(3.2)	P7	D23	U	—	31-221-RFX	2 ▲
		1.06(27.0)	.500(12.7)	.469(11.9)	.156(4.0)	P1	D1	T	UG-625B/U	31-236*	2 ▲
		1.19(30.2)	.500(12.7)	.481(12.3)	.250(6.4)	P1	D1	U	UG-1094A/U	31-2221	2
Front Mount, Gold Plated Contact	Solder Cup	1.19(30.2)	.500(12.7)	.484(12.3)	.250(6.4)	P34	D1	U	M39012/21-0002	31-3376*	2
Front Mount, Pressurized	Solder Cup	1.30(32.9)	.578(14.7)	.594(15.1)	.250(6.4)	P1	D9	P	UG-657A/U	31-239*	2 ▲
Front Mount, Pressurized	Solder Cup	1.30(32.9)	.578(14.7)	.594(15.1)	.250(6.4)	P1	D9	P	UG-657/U	31-102*	2
Fr. Mount, Gold Plated Contact	Spade	1.20(30.6)	.594(15.1)	.516(13.1)	.250(6.4)	P33	D1	U	M39012/24-0002	31-4238*	2
Hermetic External Tooth Lockwasher	Spade	1.20(30.6)	.594(15.1)	.516(13.1)	.250(6.4)	P1	D/11	U	UG-912/U	31-238*	2
Front Mount	Solder Cup	1.06(27.0)	.500(12.7)	.472(12.0)	.156(4.0)	P1	D1	T	UG-625/U	5575*	2 ▲
Rear Mount, Hermetic	Spade	1.34(34.0)	.687(17.4)	.831(21.1)	.250(6.4)	P33	D1/11	Y	M39012/24-0001	31-4237*	3
Front Mount Isolated from Panel Metal Mounting Threads	Solder Cup	1.06(27.0)	.625(15.9)	.571(14.5)	.187(4.7)	P4	D1	Y	—	31-4890-1	4

\* recognized under the component program of U.L., Inc. ▲ distributor stocked