

Excellent Integrated System Limited

Stocking Distributor

Click to view price, real time Inventory, Delivery & Lifecycle Information:

[International Rectifier \(Infineon Technologies Americas Corp.\)
IRF7353D2TRPBF](#)

For any questions, you can email us directly:

sales@integrated-circuit.com

International IR Rectifier

PD- 95215A

IRF7353D2PbF

FETKY™ MOSFET / Schottky Diode

- Co-Pack HEXFET® Power MOSFET and Schottky Diode
- Ideal For Buck Regulator Applications
- N-Channel HEXFET power MOSFET
- Low V_F Schottky Rectifier
- Generation 5 Technology
- SO-8 Footprint
- Lead-Free

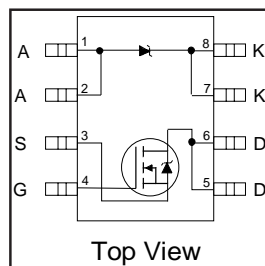

$V_{DSS} = 30V$
$R_{DS(on)} = 0.029\Omega$
Schottky $V_F = 0.52V$

Description

The FETKY™ family of Co-Pack HEXFET® Power MOSFETs and Schottky diodes offers the designer an innovative, board space saving solution for switching regulator and power management applications. Generation 5 HEXFET power MOSFETs utilize advanced processing techniques to achieve extremely low on-resistance per silicon area. Combining this technology with International Rectifier's low forward drop Schottky rectifiers results in an extremely efficient device suitable for use in a wide variety of portable electronics applications.

The SO-8 has been modified through a customized leadframe for enhanced thermal characteristics. The SO-8 package is designed for vapor phase, infrared or wave soldering techniques.

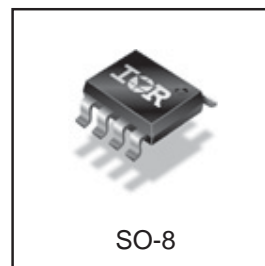

Absolute Maximum Ratings ($T_A = 25^\circ C$ unless otherwise noted)

Parameter		Maximum	Units
$I_D @ T_A = 25^\circ C$	Continuous Drain Current ④	6.5	A
$I_D @ T_A = 70^\circ C$		5.2	
I_{DM}	Pulsed Drain Current ①	52	
$P_D @ T_A = 25^\circ C$	Power Dissipation ④	2.0	W
$P_D @ T_A = 70^\circ C$		1.3	
	Linear Derating Factor	16	mW/°C
V_{GS}	Gate-to-Source Voltage	± 20	V
dv/dt	Peak Diode Recovery dv/dt ②	-5.0	V/ns
T_J, T_{STG}	Junction and Storage Temperature Range	-55 to +150	°C

Thermal Resistance Ratings

Parameter		Maximum	Units
$R_{\theta JA}$	Junction-to-Ambient ③	62.5	°C/W

Notes:

- ① Repetitive rating; pulse width limited by maximum junction temperature (see figure 9)
 - ② Starting $T_J = 25^\circ C$, $L = 10mH$, $R_G = 25\Omega$, $I_{AS} = 4.0A$
 - ③ $I_{SD} \leq 4.0A$, $di/dt \leq 74A/\mu s$, $V_{DD} \leq V_{(BR)DSS}$, $T_J \leq 150^\circ C$
 - ④ Pulse width $\leq 300\mu s$; duty cycle $\leq 2\%$
- ⑤ Surface mounted on FR-4 board, $t \leq 10sec$.

www.irf.com

IRF7353D2PbF

 International

MOSFET Electrical Characteristics @ $T_J = 25^\circ\text{C}$ (unless otherwise specified)

Parameter	Min.	Typ.	Max.	Units	Conditions
$V_{(BR)DSS}$	30	—	—	V	$V_{GS} = 0V, I_D = 250\mu A$
$R_{DS(on)}$	—	0.023	0.029	Ω	$V_{GS} = 10V, I_D = 5.8A$ ④
	—	0.032	0.046		$V_{GS} = 4.5V, I_D = 4.7A$ ④
$V_{GS(th)}$	1.0	—	—	V	$V_{DS} = V_{GS}, I_D = 250\mu A$
g_{fs}	—	14	—	S	$V_{DS} = 24V, I_D = 5.8A$
I_{DSS}	—	—	1.0	μA	$V_{DS} = 24V, V_{GS} = 0V$
	—	—	25		$V_{DS} = 24V, V_{GS} = 0V, T_J = 55^\circ\text{C}$
I_{GSS}	—	—	100	nA	$V_{GS} = 20V$
	—	—	-100		$V_{GS} = -20V$
Q_g	—	22	33	nC	$I_D = 5.8A$
Q_{gs}	—	2.6	3.9		$V_{DS} = 24V$
Q_{gd}	—	6.4	9.6		$V_{GS} = 10V$ (see figure 8) ④
$t_{d(on)}$	—	8.1	12	ns	$V_{DD} = -5V$
t_r	—	8.9	13		$I_D = 1.0A$
$t_{d(off)}$	—	26	39		$R_G = 6.0\Omega$
t_f	—	18	26		$R_D = 15\Omega$ ④
C_{iss}	—	650	—	pF	$V_{GS} = 0V$
C_{oss}	—	320	—		$V_{DS} = 25V$
C_{rss}	—	130	—		$f = 1.0\text{MHz}$ (see figure 7)

MOSFET Source-Drain Ratings and Characteristics

Parameter	Min.	Typ.	Max.	Units	Conditions
I_S	—	—	2.5	A	
I_{SM}	—	—	30		
V_{SD}	—	0.78	1.0	V	$T_J = 25^\circ\text{C}, I_S = 1.7A, V_{GS} = 0V$
t_{rr}	—	45	68	ns	$T_J = 25^\circ\text{C}, I_F = 1.7A$
Q_{rr}	—	58	87	nC	$di/dt = 100A/\mu s$ ③

Schottky Diode Maximum Ratings

Parameter	Max.	Units	Conditions
$I_{F(av)}$	3.2	A	50% Duty Cycle. Rectangular Wave, $T_c = 25^\circ\text{C}$
	2.0		50% Duty Cycle. Rectangular Wave, $T_c = 70^\circ\text{C}$
I_{SM}	200	A	5 μs sine or 3 μs Rect. pulse
	20		10ms sine or 6ms Rect. pulse
			Following any rated load condition & with V_{rrm} applied

Schottky Diode Electrical Specifications

Parameter	Max.	Units	Conditions
V_{FM}	0.57	V	$I_f = 3.0, T_j = 25^\circ\text{C}$
	0.77		$I_f = 6.0, T_j = 25^\circ\text{C}$
	0.52		$I_f = 3.0, T_j = 125^\circ\text{C}$
	0.79		$I_f = 6.0, T_j = 125^\circ\text{C}$
I_{rm}	0.30	mA	$V_r = 30V, T_j = 25^\circ\text{C}$
	37		$T_j = 125^\circ\text{C}$
C_t	310	pF	$V_r = 5V_{dc}$ (100kHz to 1 MHz) 25°C
dv/dt	4900	V/ μs	Rated V_r

(HEXFET is the reg. TM for International Rectifier Power MOSFET's)

International
IR Rectifier

IRF7353D2PbF

Power MOSFET Characteristics

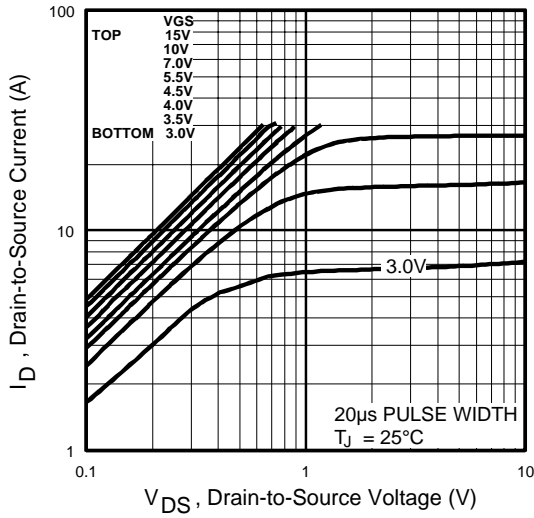

Fig 1. Typical Output Characteristics

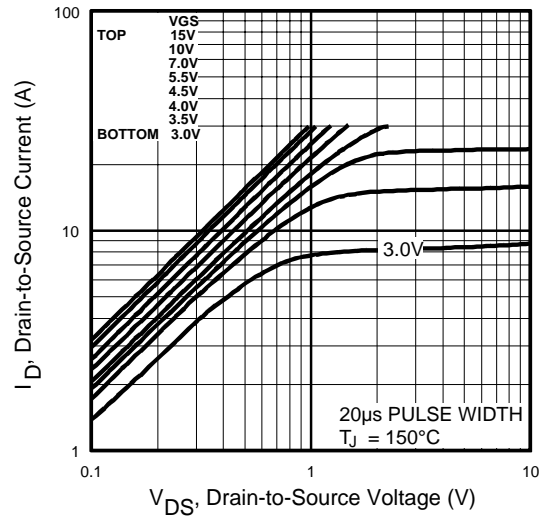

Fig 2. Typical Output Characteristics

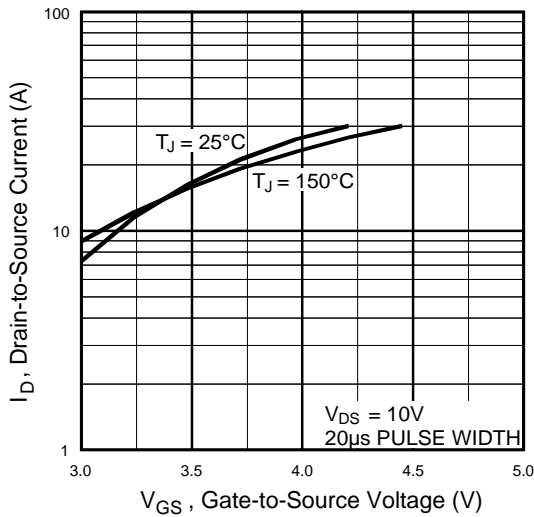

Fig 3. Typical Transfer Characteristics

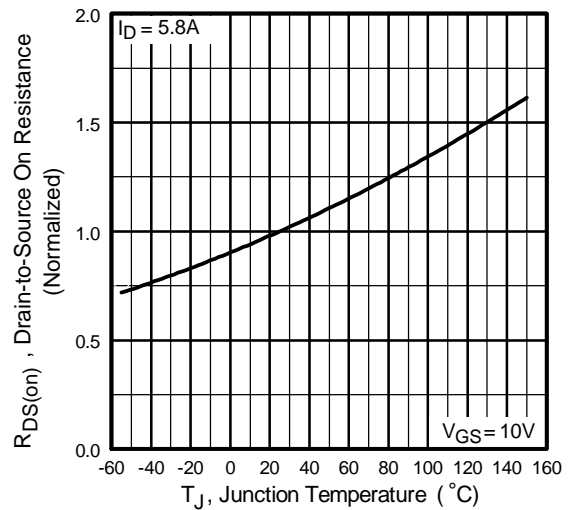

Fig 4. Normalized On-Resistance Vs. Temperature

IRF7353D2PbF

International
IR Rectifier

Power MOSFET Characteristics

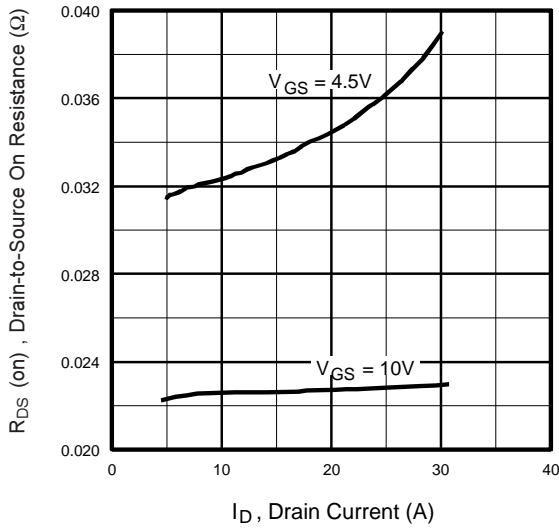

Fig 5. Typical On-Resistance Vs. Drain Current

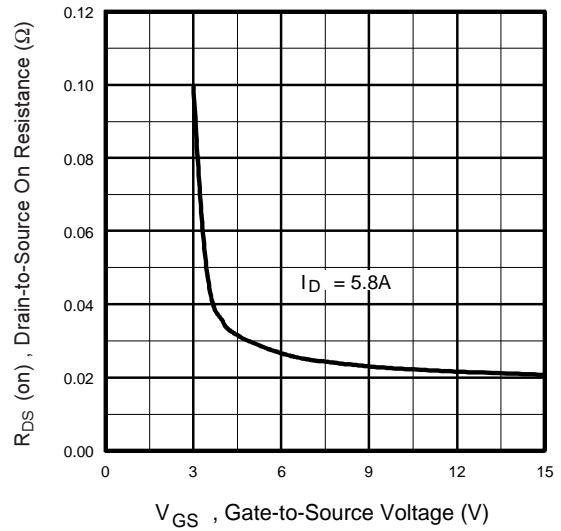

Fig 6. Typical On-Resistance Vs. Gate Voltage

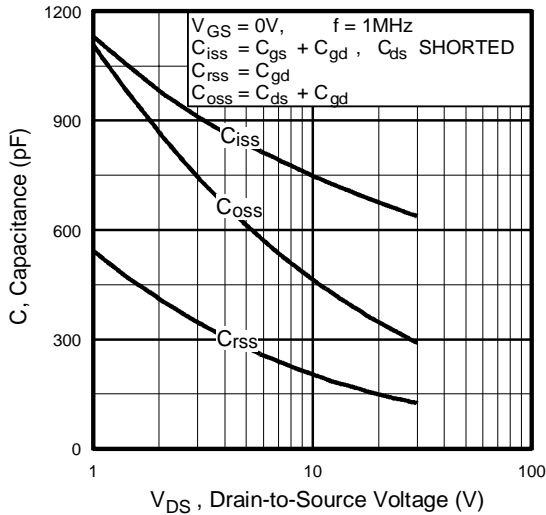

Fig 7. Typical Capacitance Vs. Drain-to-Source Voltage

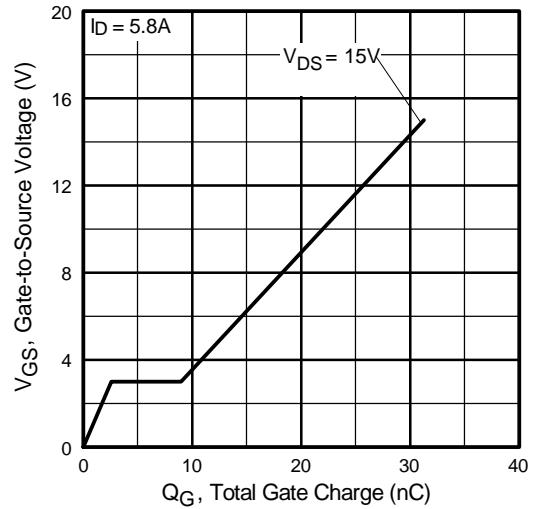

Fig 8. Typical Gate Charge Vs. Gate-to-Source Voltage

International
IR Rectifier

IRF7353D2PbF

Power MOSFET Characteristics

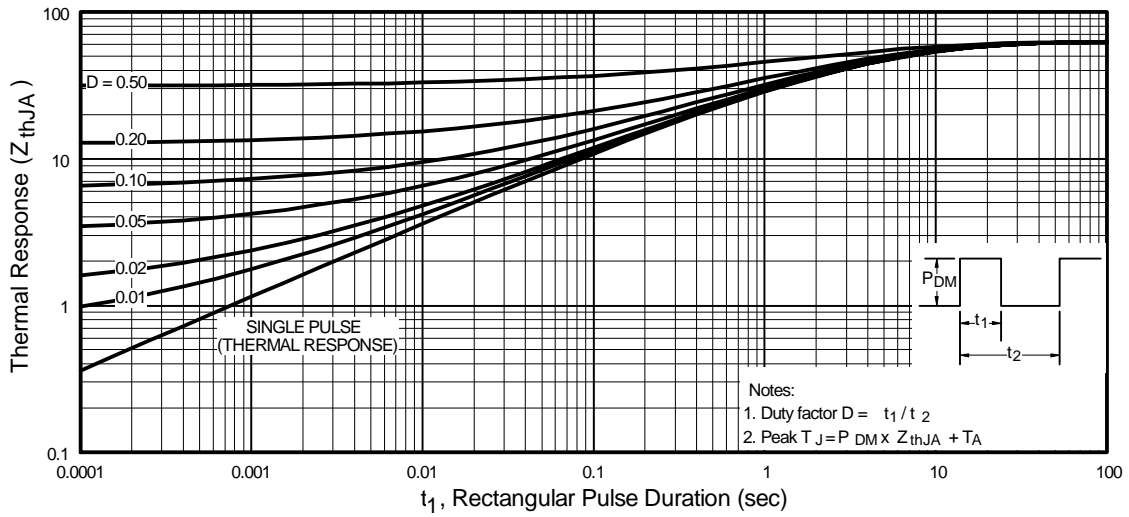

Fig 9. Maximum Effective Transient Thermal Impedance, Junction-to-Ambient

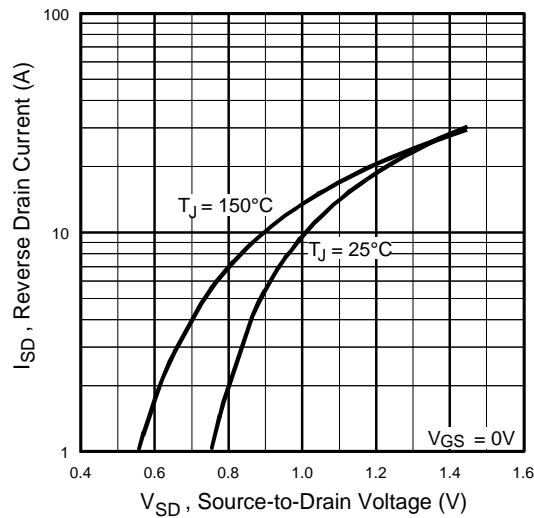

Fig 10. Typical Source-Drain Diode Forward Voltage

IRF7353D2PbF

International
IR Rectifier

Schottky Diode Characteristics

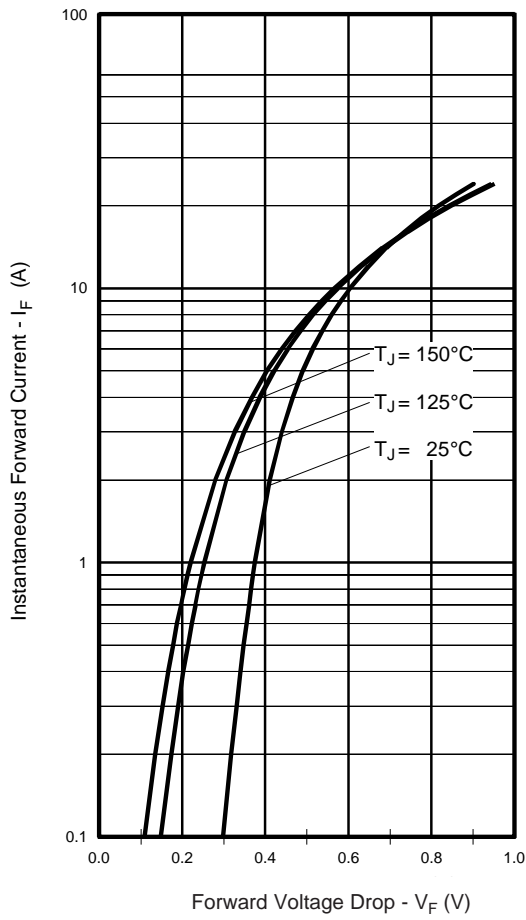

Fig. 12 - Typical Forward Voltage Drop Characteristics

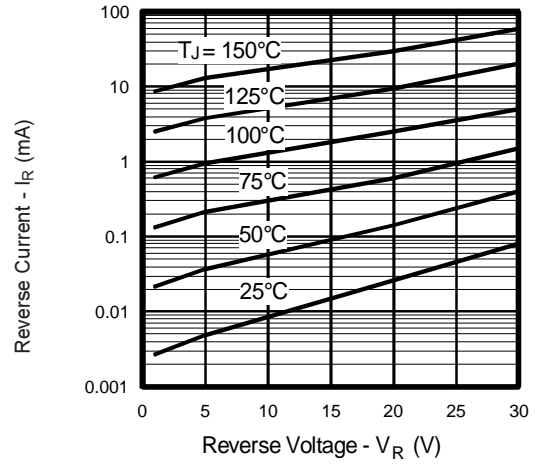

Fig. 13 - Typical Values of Reverse Current Vs. Reverse Voltage

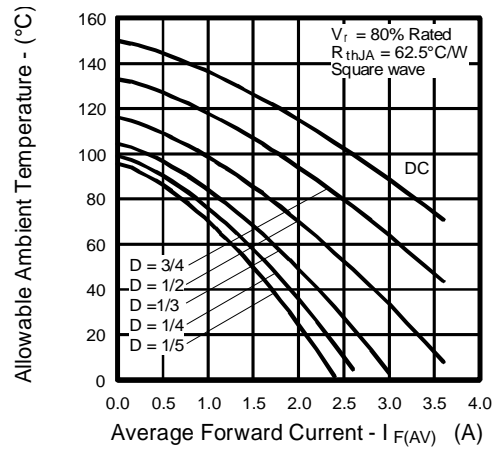

Fig.14 - Maximum Allowable Ambient Temp. Vs. Forward Current

International
IR Rectifier

IRF7353D2PbF

SO-8 (Fetky) Package Outline

Dimensions are shown in millimeters (inches)

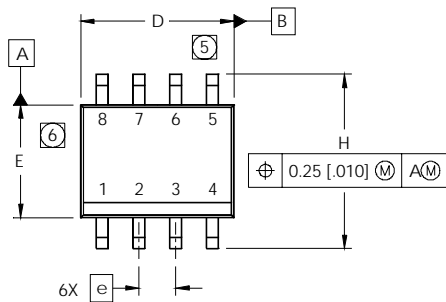

DIM	INCHES		MILLIMETERS	
	MIN	MAX	MIN	MAX
A	.0532	.0688	1.35	1.75
A1	.0040	.0098	0.10	0.25
b	.013	.020	0.33	0.51
c	.0075	.0098	0.19	0.25
D	.189	.1968	4.80	5.00
E	.1497	.1574	3.80	4.00
e	.050 BASIC		1.27 BASIC	
e1	.025 BASIC		0.635 BASIC	
H	.2284	.2440	5.80	6.20
K	.0099	.0196	0.25	0.50
L	.016	.050	0.40	1.27
y	0°	8°	0°	8°

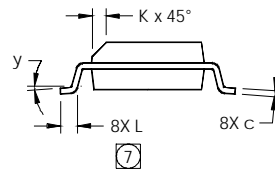
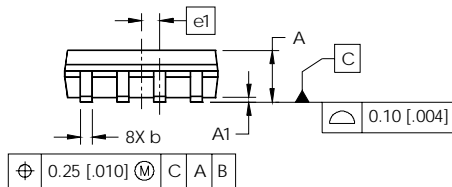

NOTES:

1. DIMENSIONING & TOLERANCING PER ASME Y14.5M-1994.
2. CONTROLLING DIMENSION: MILLIMETER
3. DIMENSIONS ARE SHOWN IN MILLIMETERS [INCHES].
4. OUTLINE CONFORMS TO JEDEC OUTLINE MS-012AA.
5. DIMENSION DOES NOT INCLUDE MOLD PROTRUSIONS. MOLD PROTRUSIONS NOT TO EXCEED 0.15 [0.006].
6. DIMENSION DOES NOT INCLUDE MOLD PROTRUSIONS. MOLD PROTRUSIONS NOT TO EXCEED 0.25 [0.010].
7. DIMENSION IS THE LENGTH OF LEAD FOR SOLDERING TO A SUBSTRATE.

FOOTPRINT

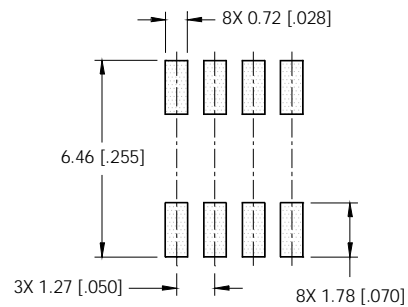

SO-8 (Fetky) Part Marking Information

EXAMPLE: THIS IS AN IRF7807D1 (FETKY)

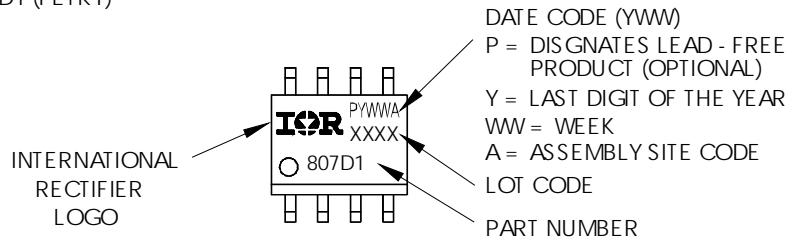

IRF7353D2PbF

International
IR Rectifier

SO-8 (Fetky) Tape and Reel

Dimensions are shown in millimeters (inches)

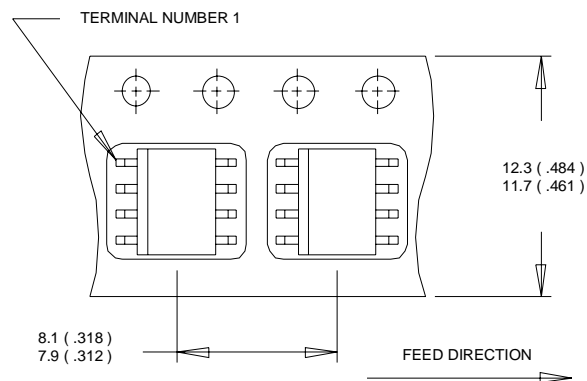

- NOTES:
1. CONTROLLING DIMENSION : MILLIMETER.
 2. ALL DIMENSIONS ARE SHOWN IN MILLIMETERS(INCHES).
 3. OUTLINE CONFORMS TO EIA-481 & EIA-541.

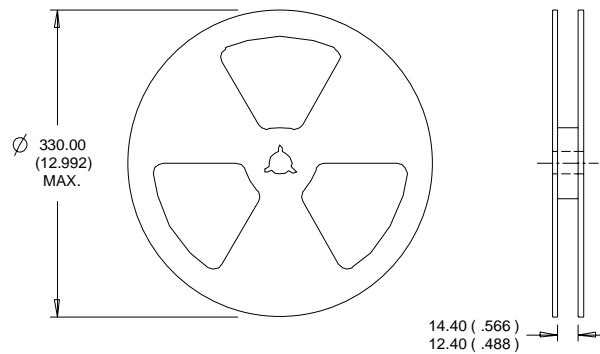

- NOTES :
1. CONTROLLING DIMENSION : MILLIMETER.
 2. OUTLINE CONFORMS TO EIA-481 & EIA-541.

Data and specifications subject to change without notice.
 This product has been designed and qualified for the Consumer market.
 Qualification Standards can be found on IR's Web site.

International
IR Rectifier

IR WORLD HEADQUARTERS: 233 Kansas St., El Segundo, California 90245, USA Tel: (310) 252-7105
 TAC Fax: (310) 252-7903

Visit us at www.irf.com for sales contact information.10/04

www.irf.com