

## Excellent Integrated System Limited

Stocking Distributor

Click to view price, real time Inventory, Delivery & Lifecycle Information:

[Sharp Microelectronics](#)  
[PQ1CZ41H2ZZH](#)

For any questions, you can email us directly:

[sales@integrated-circuit.com](mailto:sales@integrated-circuit.com)

**SHARP**

PQ1CZ41H2ZxH

# PQ1CZ41H2ZxH

TO-220 Type Chopper Regulator,  
built-in 300kHz oscillation circuit

## Features

1. Maximum switching current: 1.5A
2. Built-in ON-OFF control function
3. Built-in soft start function to suppress overshoot of output voltage in power on sequence or ON/OFF control sequence
4. Built-in oscillation circuit  
(Oscillation frequency: TYP.300kHz)
5. Built-in overheat protection function, overcurrent protection function
6. SC-63 Surface Mount Type package
7. Variable output voltage  
(Output variable range:  $V_{ref}$  to  $35V$  /  $-V_{ref}$  to  $-30V$ )  
[Possible to select step-down output/inverting output according to external connection circuit]
8. **PQ1CZ41H2ZZH**: Sleeve-packaged product  
**PQ1CZ41H2ZPH**: Tape-packaged product
9. RoHS directive compliant

## Applications

1. Color TV, STB
2. LCD monitors
3. Facsimiles, plinters and other OA equipment
4. CD-ROM drives/DVD-ROM drivers
5. Air conditioners

## Absolute Maximum Ratings

( $T_a=25^\circ\text{C}$ )

Parameter	Symbol	Rating	Unit
*1 Input voltage	$V_{IN}$	40	V
Error input voltage	$V_{ADJ}$	7	V
Input - output voltage	$V_{I-O}$	41	V
*2 Output - COM voltage	$V_{OUT}$	-1	V
*3 ON/OFF control voltage	$V_C$	-0.3 to +40	V
Switching current	$I_{SW}$	1.5	A
*4 Power dissipation	$P_D$	8	W
*5 Junction temperature	$T_j$	150	$^\circ\text{C}$
Operating temperature	$T_{opr}$	-40 to +85	$^\circ\text{C}$
Storage temperature	$T_{stg}$	-40 to +150	$^\circ\text{C}$
Soldering temperature	$T_{sol}$	260(10s)	$^\circ\text{C}$

\*1 Voltage between  $V_{IN}$  terminal and COM terminal

\*2 Voltage between  $V_{OUT}$  terminal and COM terminal

\*3 Voltage between ON/OFF control and COM terminal

\*4  $P_D$ : With infinite heat sink

\*5 There is case that over heat protection function operates at the temperature  $T_j=125^\circ\text{C}$  to  $150^\circ\text{C}$ , so this item cannot be used in this temperature range.

## Outline Dimensions

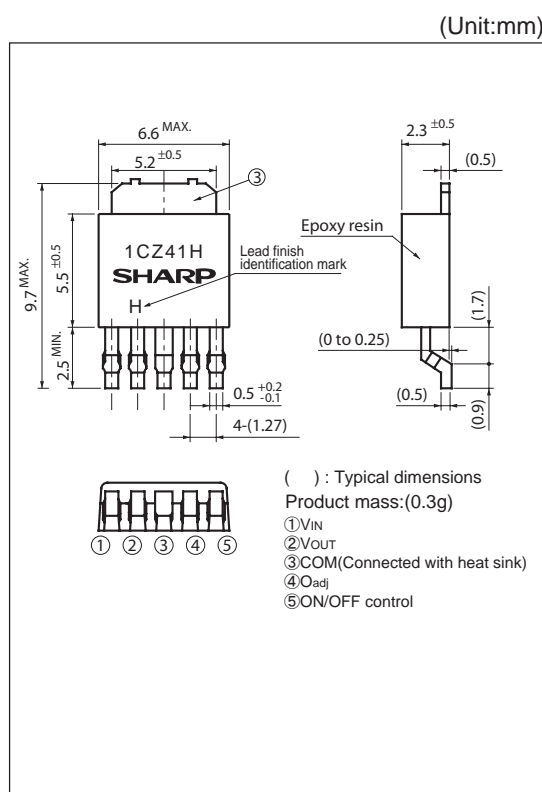

Lead finish: Lead-free solder plating  
(Composition: Sn2Cu)



**PQ1CZ41H2ZZH**

**Electrical Characteristics**

(Unless otherwise specified, condition shall be  $V_{IN}=12V, I_o=0.2A, V_o=5V$ , ON-OFF terminals is open,  $T_a=25^\circ C$ )

Parameter	Symbol	Conditions	MIN.	TYP.	MAX.	Unit
Output saturation voltage	$V_{SAT}$	$I_{sw}=1A$	—	0.9	1.5	V
Reference voltage	$V_{ref}$	—	1.235	1.26	1.285	V
Reference voltage temperature fluctuation	$\Delta V_{ref}$	$T_j=0$ to $125^\circ C$	—	$\pm 0.5$	—	%
Load regulation	$ R_{regL} $	$I_o=0.2$ to $1A$	—	0.2	1.5	%
Line regulation	$ R_{reg} $	$V_{IN}=8$ to $35V$	—	1.2	2.5	%
Efficiency	$\eta$	$I_o=1A$	—	84	—	%
Oscillation frequency	$f_o$	—	270	300	330	kHz
Oscillation frequency temperature fluctuation	$\Delta f_o$	$T_j=0$ to $125^\circ C$	—	$\pm 3$	—	%
Overcurrent detecting level	$I_L$	Switching current peak	1.55	2.0	2.6	A
Charge current	$I_{CHG}$	②,④ terminals is open,⑤ terminal	—	-10	—	$\mu A$
Input threshold voltage	$V_{THL}$	Duty ratio=0%,④ terminal=0V,⑤ terminal	—	1.3	—	V
	$V_{THH}$	Duty ratio=100%,④ terminal=1.1V, ⑤ terminal	—	2.3	—	V
ON threshold voltage	$V_{TH(ON)}$	④ terminal=0V,⑤ terminal	0.7	0.8	0.9	V
Stand-by current	$I_{SD}$	$V_{IN}=40V$ ,⑤ terminal=0V	—	140	400	$\mu A$
Output OFF-state dissipation current	$I_{QS}$	$V_{IN}=40V$ ,④ terminal=0V,⑤ terminal=0.9V	—	8	12	mA

Fig.1 Test Circuit

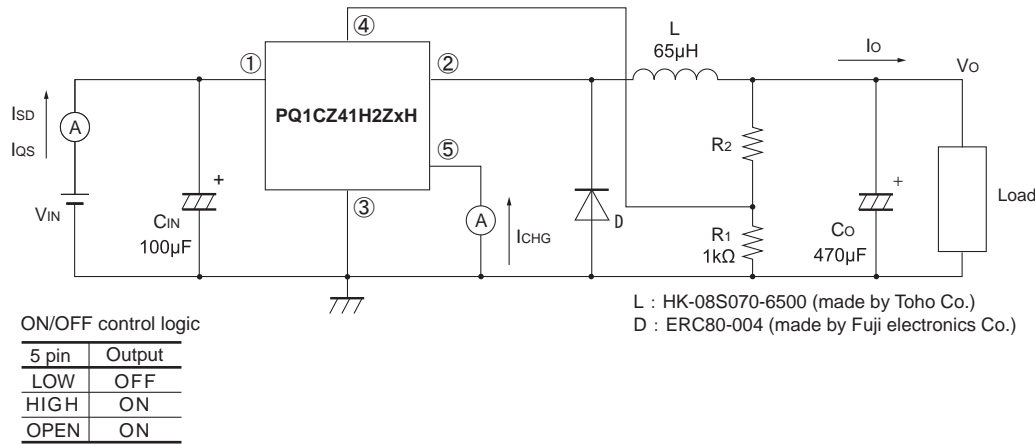
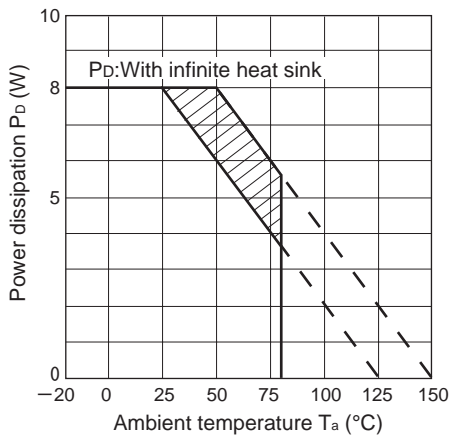

Fig.2 Power Dissipation vs.Ambient Temperature



Note) Oblique line portion: Overheat protection may operate in this area

Fig.3 Overcurrent Protection Characteristics (Typical Value)

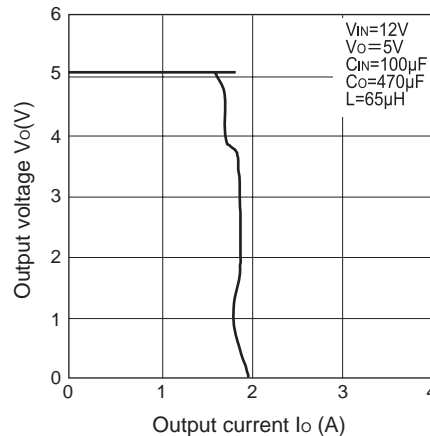

Fig.4 Efficiency vs. Input Voltage

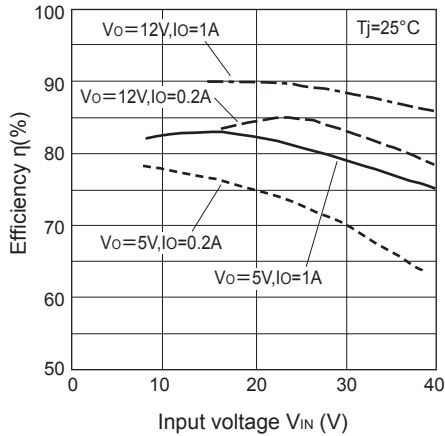

Fig.5 Output Saturation Voltage vs. Switching Current

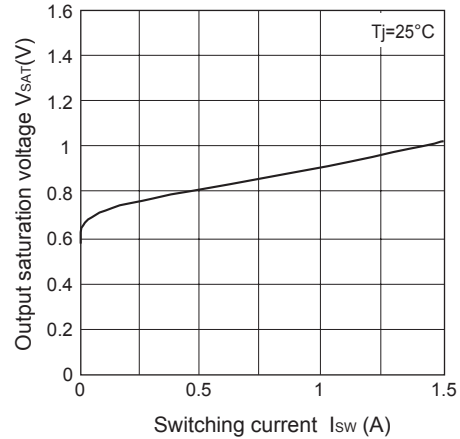

Fig.6 Stand-by Current vs. Input Voltage

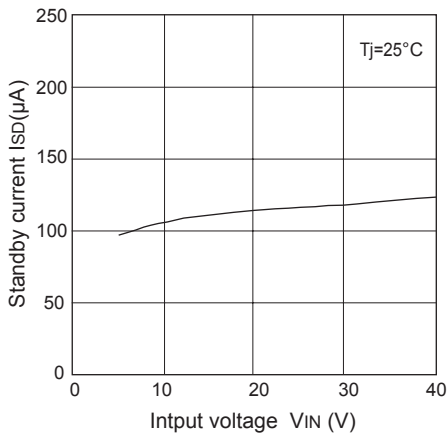

Fig.7 Reference Voltage Fluctuation vs. Junction Temperature

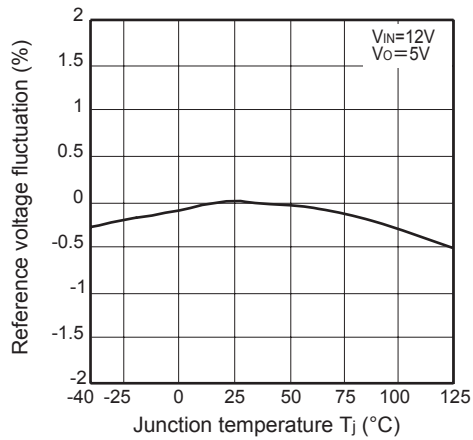

Fig.8 Load Regulation vs. Output Current

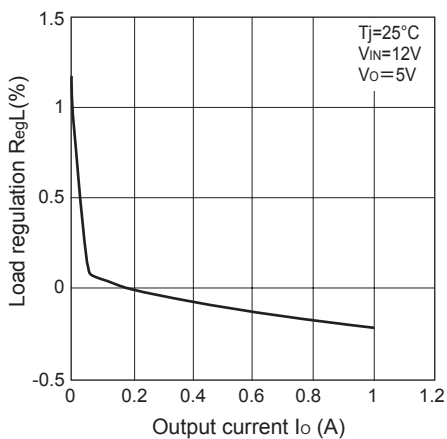

Fig.9 Line Regulation vs. Input Voltage

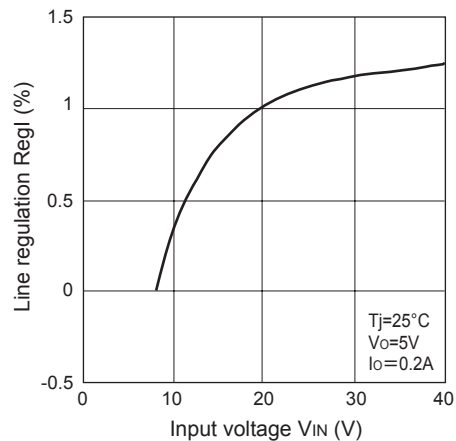

Fig.10 Oscillation Frequency Fluctuation vs. Junction Temperature

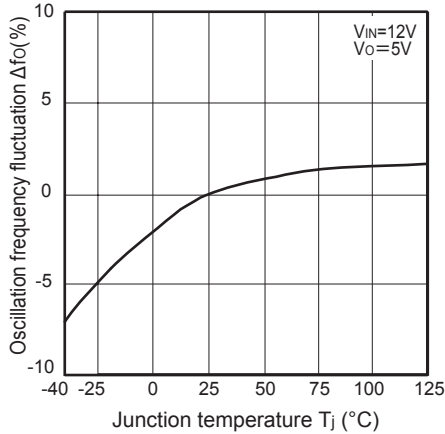

Fig.11 Overcurrent Detecting Level Fluctuation vs. Junction Temperature

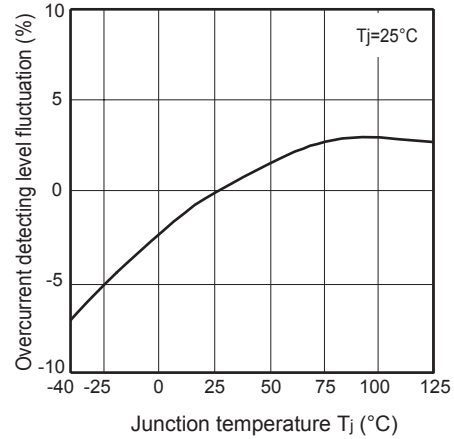

Fig.12 On Threshold Voltage vs. Junction Temperature

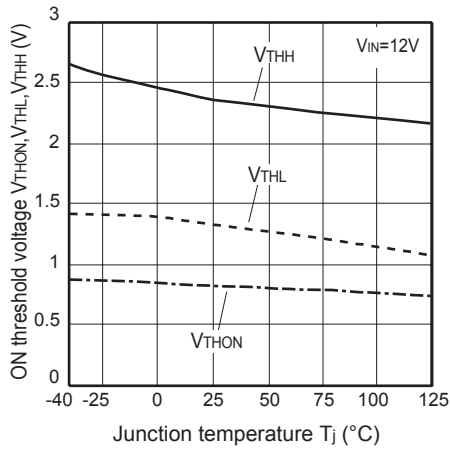

Fig.13 Operating Dissipation Current vs. Input Voltage

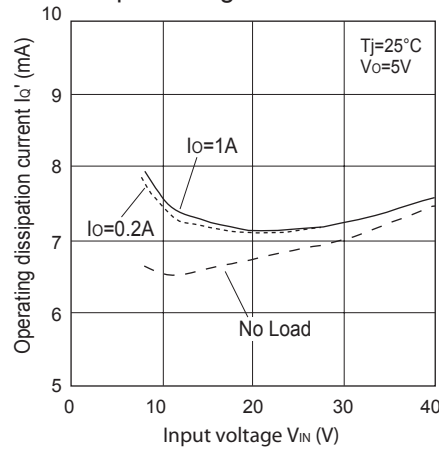
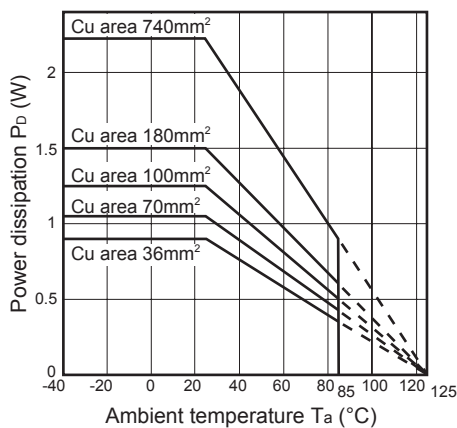
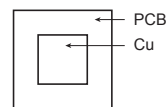

Fig.14 Power Dissipation vs. Ambient Temperature (Typical Value)



Mounting PCB



Material : Glass-cloth epoxy resin  
Size : 50×50×1.6mm  
Cu thickness : 35μm

Fig.15 Block Diagram

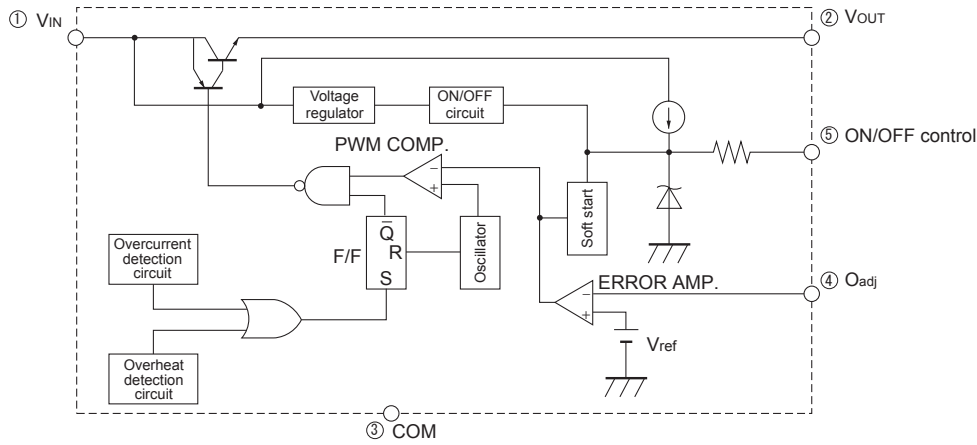

Fig.16 Step Down Type Circuit Diagram

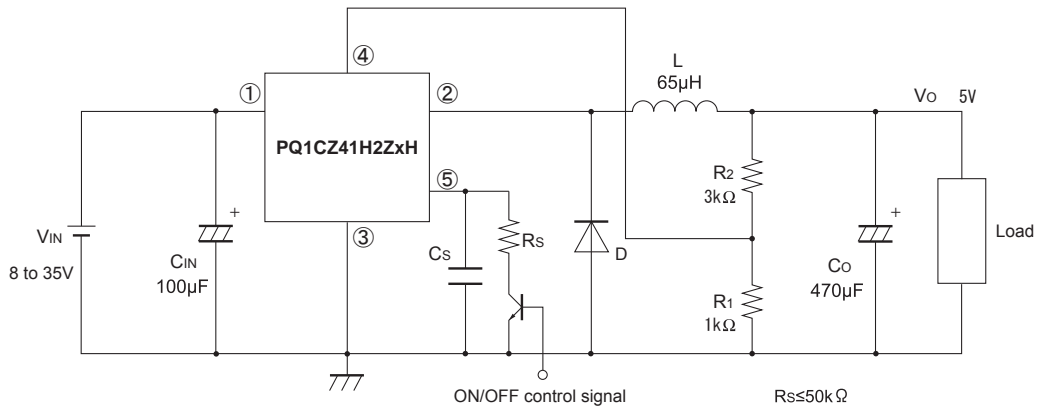
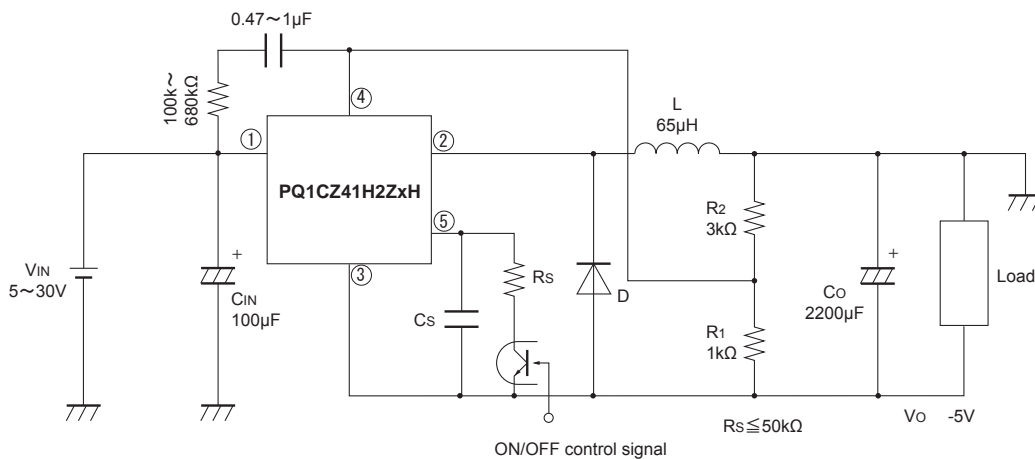

Fig.17 Polarity Inversion Type Circuit Diagram



In case that polarity is reverse, depending on the conditions, there is cases that output voltage can not gain, please use this device after confirming the output voltage at the actual conditions.