

Excellent Integrated System Limited

Stocking Distributor

Click to view price, real time Inventory, Delivery & Lifecycle Information:

[Diodes Incorporated](#)
[BS170P](#)

For any questions, you can email us directly:

sales@integrated-circuit.com

N-CHANNEL ENHANCEMENT MODE VERTICAL DMOS FET

ISSUE 2 – SEPT 93

BS170P

FEATURES

- * 60 Volt V_{DS}
- * $R_{DS(on)}=5\Omega$

REFER TO ZVN3306A FOR GRAPHS

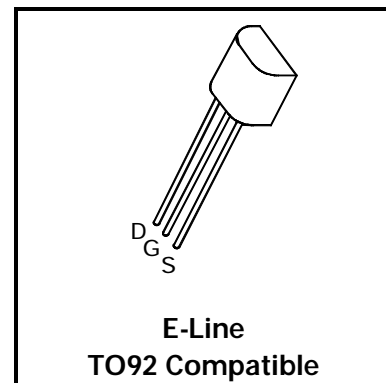

ABSOLUTE MAXIMUM RATINGS.

PARAMETER	SYMBOL	VALUE	UNIT
Drain-Source Voltage	V_{DS}	60	V
Continuous Drain Current at $T_{amb}=25^{\circ}C$	I_D	270	mA
Pulsed Drain Current	I_{DM}	3	A
Gate-Source Voltage	V_{GS}	± 20	V
Power Dissipation at $T_{amb}=25^{\circ}C$	P_{tot}	625	mW
Operating and Storage Temperature Range	$T_j: T_{stg}$	-55 to +150	$^{\circ}C$

ELECTRICAL CHARACTERISTICS (at $T_{amb} = 25^{\circ}C$).

PARAMETER	SYMBOL	MIN.	TYP.	MAX.	UNIT	CONDITIONS.
Drain-Source Breakdown Voltage	BV_{DSS}	60			V	$I_D=100\mu A, V_{GS}=0V$
Gate-Source Threshold Voltage	$V_{GS(th)}$	0.8		3	V	$I_D=1mA, V_{DS}=V_{GS}$
Gate Body Leakage	I_{GSS}			10	nA	$V_{GS}=15V, V_{DS}=0V$
Zero Gate Voltage Drain Current	I_{DSS}			0.5	μA	$V_{GS}=0V, V_{DS}=25V$
Static Drain-Source on-State Resistance (1)	$R_{DS(on)}$			5	Ω	$V_{GS}=10V, I_D=200mA$
Forward Transconductance (1)(2)	g_{fs}		200		mS	$V_{DS}=10V, I_D=200mA$
Input Capacitance (2)	C_{iss}		60		pF	$V_{GS}=0V, V_{DS}=10V$ $f=1MHz$
Turn-On Time (2)(3)	$t_{(on)}$			10	ns	$V_{DD}\approx 15V, I_D=600mA$
Turn-Off Time (2)(3)	$t_{(off)}$			10	ns	

 (1) Measured under pulsed conditions. Pulse width=300 μs . Duty cycle $\leq 2\%$ (2) Sample test

 (3) Switching times measured with a 50 Ω source impedance and <5ns rise time on a pulse generator