

Excellent Integrated System Limited

Stocking Distributor

Click to view price, real time Inventory, Delivery & Lifecycle Information:

[Bel Fuse Inc.](#)
[142-0003-206](#)

For any questions, you can email us directly:
sales@integrated-circuit.com

Shielded Cable Termination

Flexible Cable - Straight Crimp Type

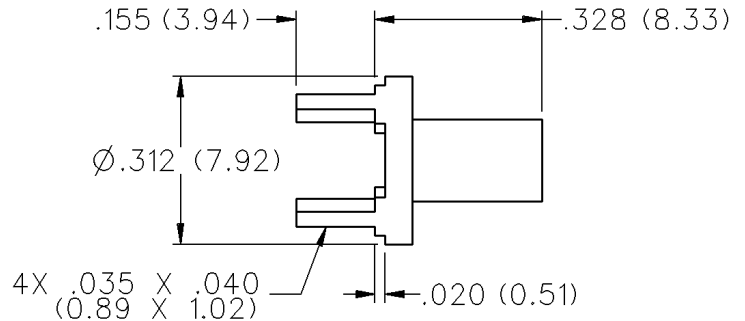

CABLE TYPE	GOLD PLATED	NICKEL PLATED
RG-161/U, 174, 179, 187, 188, 316	142-0003-201	142-0003-206

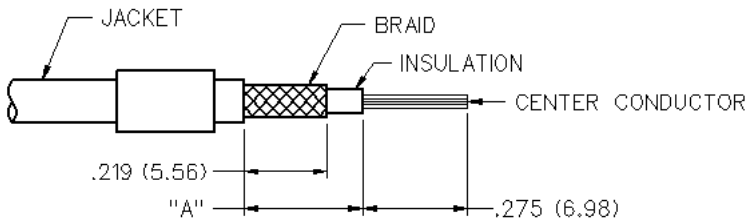
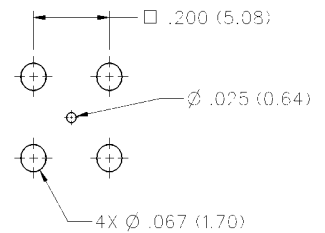
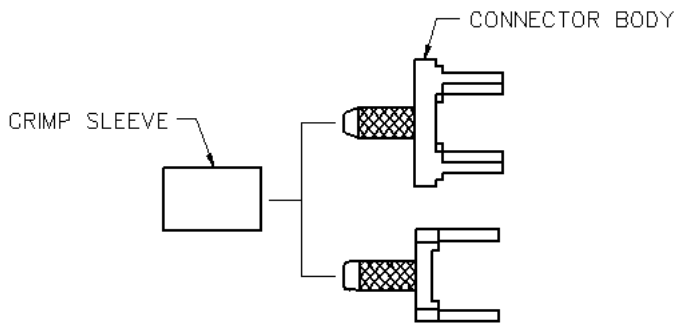

1. Identify connector parts. (2 piece parts)
2. Strip cable to dimensions shown. Do not nick braid or center conductor. A wire stripper of correct size is recommended for this step. Twist stranded center conductor into tight bundle and tin. Slide crimp sleeve onto cable as shown.
3. Flare braid and slide cable into body making certain that the cable insulation is flush with bottom of connector.
4. Arrange braid uniformly around crimp stem. Slide crimp sleeve over braid and crimp securely using recommended crimp tool.

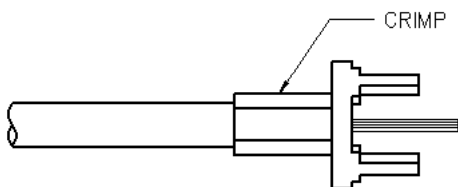
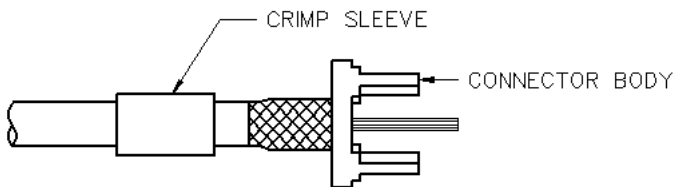

CABLE GROUP	PART NUMBER	"A"	CRIMP HEX
RG-316/u, 161, 174, 179, 179, 187, 188	142-0003-201/206	.312 (7.92)	.128 (3.25)