

Excellent Integrated System Limited

Stocking Distributor

Click to view price, real time Inventory, Delivery & Lifecycle Information:

[TE Connectivity](#)
[MGDQ6-00009](#)

For any questions, you can email us directly:

sales@integrated-circuit.com

| | | | |
|----------------|--|--|---|
| SERIES: |  | 3003 9th Avenue SW PO Box 50 Watertown, SD 57201 Toll free: 888-978-2638 Ph: 605-886-3326 Fax: 605-886-8995 |  |
| MGDQ6 |  | Low Profile, High Current Power Inductors | |

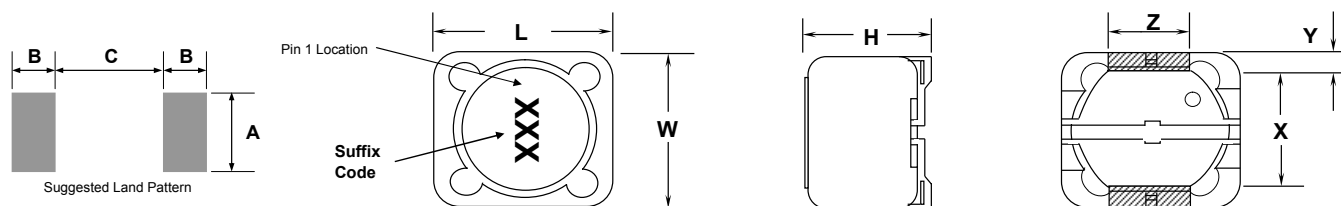

| Series Number | Maximum Dimensions | | | | Reference Dimensions | | | | | |
|---------------|--------------------|-----------|-----------|----------|----------------------|----------|----------|----------|----------|----------|
| | Units | L | W | H | X | Y | Z | A | B | C |
| MGDQ6 | inches | 0.492" | 0.492" | 0.315" | 0.315" | 0.087" | 0.197" | 0.202" | 0.084" | 0.307" |
| | [mm] | [12.50] | [12.50] | [8.00] | [8.00] | [2.20] | [5.00] | [5.13] | [2.13] | [7.80] |

Features:

- High energy storage and low resistance
- Reliable surface mounting, flat top for pick and place.
- Smaller real estate than other common inductors.
- Robust temperature deflection to prevent damage during solder reflow.
- Tape and Reel mechanical specifications available upon request.
- Operating Temperature -40°C to +85°C.
- Highly resistive core for EMI suppression applications.

Notes:

- Inductance measured at 100kHz and 250mVrms.
- Isat is a maximum applied AC + DC current.
- Isat current is applied to produce a typical 35% drop in nominal inductance.
- Tolerance suffix of M = ±20%.
- DCR is a maximum at 25°C.



260°C Maximum reflow temperature per J-STD020
Terminal Plating is Gold Flash over Ni

Schematic Diagram

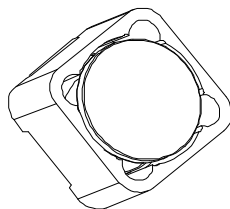
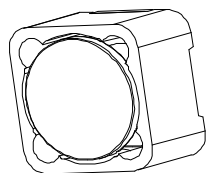
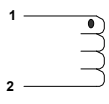

| Lead Free Part Number | L µH | MGDQ6 | | Tolerance Suffix |
|-----------------------|---------|----------|-----------|------------------|
| | | DCR Ω | Isat A | |
| MGDQ6-00001 | 0.47 | 0.0020 | 35.000 | M |
| MGDQ6-00002 | 0.75 | 0.0025 | 33.00 | M |
| MGDQ6-00003 | 1.5 | 0.003 | 25.00 | M |
| MGDQ6-00004 | 2.4 | 0.012 | 8.00 | M |
| MGDQ6-00005 | 3.5 | 0.014 | 7.50 | M |
| MGDQ6-00006 | 4.7 | 0.016 | 13.50 | M |
| MGDQ6-00007 | 6.1 | 0.018 | 6.60 | M |
| MGDQ6-00008 | 7.6 | 0.020 | 5.90 | M |
| MGDQ6-00009 | 10 | 0.022 | 5.40 | M |
| MGDQ6-00010 | 12 | 0.025 | 4.90 | M |
| MGDQ6-00011 | 15 | 0.027 | 4.50 | M |
| MGDQ6-00012 | 18 | 0.040 | 3.90 | M |
| MGDQ6-00013 | 22 | 0.044 | 3.60 | M |
| MGDQ6-00014 | 27 | 0.046 | 3.40 | M |
| MGDQ6-00015 | 33 | 0.065 | 3.00 | M |
| MGDQ6-00016 | 39 | 0.073 | 2.75 | M |
| MGDQ6-00017 | 47 | 0.100 | 2.50 | M |
| MGDQ6-00018 | 56 | 0.110 | 2.35 | M |
| MGDQ6-00019 | 68 | 0.140 | 2.10 | M |
| MGDQ6-00020 | 82 | 0.160 | 1.95 | M |
| MGDQ6-00021 | 100 | 0.220 | 1.70 | M |
| MGDQ6-00022 | 120 | 0.250 | 1.60 | M |
| MGDQ6-00023 | 150 | 0.280 | 1.42 | M |
| MGDQ6-00024 | 180 | 0.350 | 1.30 | M |
| MGDQ6-00025 | 220 | 0.390 | 1.16 | M |
| MGDQ6-00026 | 270 | 0.560 | 1.06 | M |
| MGDQ6-00027 | 330 | 0.640 | 0.95 | M |
| MGDQ6-00028 | 390 | 0.700 | 0.88 | M |
| MGDQ6-00029 | 470 | 0.980 | 0.79 | M |
| MGDQ6-00030 | 560 | 1.070 | 0.93 | M |
| MGDQ6-00031 | 680 | 1.460 | 0.67 | M |
| MGDQ6-00032 | 820 | 1.640 | 0.60 | M |
| MGDQ6-00033 | 1000 | 1.820 | 0.55 | M |

Contact CoEv for additional inductance values

Specifications subject to change

Call Toll Free: 888-978-2638 Website: www.tycopowercomponents.com

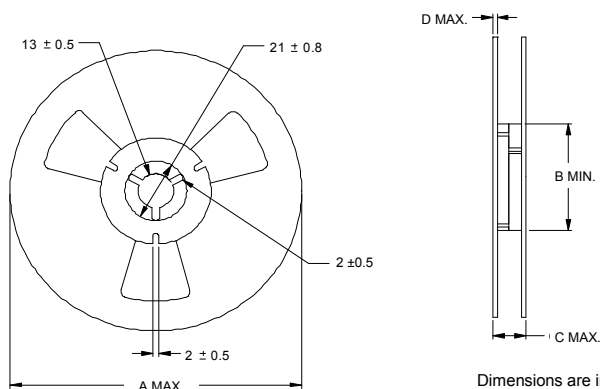

Dimensions are in millimeters unless specified.

| Series Number | Reel dimensions | | | | Reel Qty | Carton (Box) Qty | Packaging Specification |
|---------------|-----------------|--------|---------|--------|----------|------------------|-------------------------|
| | Units | A | B | C | | | |
| MGDQ6 | in. | 12.99" | 3.94" | 1.16" | 300 | 1800 | 90-0054 |
| | [mm] | [330] | [100.0] | [29.5] | | | |

PACKAGING NOTE: Only pressure sensitive cover tape is to be used.

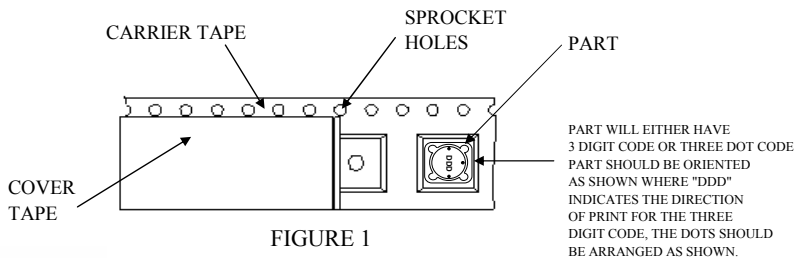
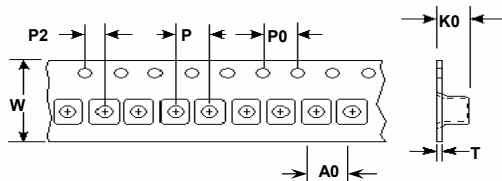

FIGURE 1
CARRIER TAPE AND PART



| Series | W ±0.3 | P ±0.1 | P0 ±0.1 | P2 ±0.1 | K0 ±0.05 | T ±0.05 | A0 ±0.1 |
|--------|--------|--------|---------|---------|----------|---------|---------|
| MGDQ6 | 24.0 | 16.0 | 4.00 | 2.00 | 8.25 | 0.35 | 12.6 |



Customer Packaging Specifications
For Print Distribution to Customers

| Series | Revision |
|--------|----------|
| MGDQ6 | A0 |

| Item | Specification | Test Method/Condition |
|--------------------------------|--|--|
| Environmental | | |
| Static Humidity | After exposure part remains within specified electrical parameters for L, Q and DCR. | Precondition at 25°C for 60 minutes. Expose parts to an environment of +40°C with 90 to 95% R.H. for 240 hours. |
| Storage Life | After exposure part remains within specified electrical parameters for L, Q and DCR. | Subject parts to an environment of 85°C 85% R.H. for 168 hours. After exposure allow parts to dry for 4 hours before measurements are taken. |
| Temperature Cycle | After exposure part remains within specified electrical parameters for L, Q and DCR. | 10 cycles (Air to Air) 1 cycle shall consist of: 30 minutes exposure to +85°C 30 minutes exposure to -40°C Allow 20 minutes transition between extremes. |
| Temperature Shock | After exposure part remains within specified electrical parameters for L, Q and DCR. | 10 cycles (Air to Air) 1 cycle shall consist of: 30 minutes exposure to -55°C 30 minutes exposure to +125°C 15 seconds maximum transition between temperatures |
| IR Reflow | 10 seconds at 260°C max. | Post test parts shall pass all electrical specifications after reflow. There shall be no visible signs of solder flow or leakage from the part. |
| General | | |
| Storage Temperature Range | -40°C to +85°C | |
| Operating Temperature Range | -40°C to +85°C | |
| Flammability | IEC 695-2-2 | Withstands needle-flame test |
| Other | | |
| Vibration | After exposure part remains within specified electrical parameters for L, Q and DCR. | 1 cycle of 30 minutes of the following: 5 - 7 Hz constant displacement of 0.75 inches, 5 minutes 7 - 30 Hz constant acceleration of 1.5 Gs, 10 minutes 31 - 50 Hz constant displacement of 0.33 inches, 5 minutes 50 - 500 Hz constant acceleration of 1.2 Gs, 10 minutes |
| Mechanical Shock | After exposure part remains within specified electrical parameters for L, Q and DCR. | MGDQ1 Series - 500 Gs per axis, 2 directions MGDQ2 Series - 500 Gs per axis, 2 directions MGDQ3 Series - 500 Gs per axis, 2 directions MGDQ4 Series - 500 Gs per axis, 2 directions MGDQ5 Series - 500 Gs per axis, 2 directions MGDQ6 Series - 500 Gs per axis, 2 directions |
| Solderability | Wetting shall cover 90% minimum of each termination | Dip pads in RMA flux, 63/37 solder (Sn/Pb) at 232°C for 5 seconds ±2 seconds. |
| Component Adhesion (Push Test) | Component shall withstand 6 lb. push force minimum without delaminating from mounting surface. | Apply and measure force with a digital force gauge set. |
| Resistance to Solvent | | Withstands 6 minutes of alcohol. Withstands 3 minutes forced spray Freon TMS |
| Chemical | | |
| Ionic Contamination | Conductivity: pH: Chlorides: Sodium: Potassium: | 11 µOhms/cm maximum 5.5 to 9 65 ppm maximum 20 ppm maximum 10 ppm maximum |



For Print Distribution to Customers

| | |
|--------------|-----------|
| Series | Revision |
| MGDQ6 | A0 |
| Sheet 3 of 6 | |