

Excellent Integrated System Limited

Stocking Distributor

Click to view price, real time Inventory, Delivery & Lifecycle Information:

[TE Connectivity](#)
[MGDU3-00009](#)

For any questions, you can email us directly:

sales@integrated-circuit.com

SERIES:		3003 9th Avenue SW PO Box 50 Watertown, SD 57201 Toll free: 888-978-2638 Ph: 605-886-3326 Fax: 605-886-8995	
MGDU3			

Low Profile, High Current Power Inductors

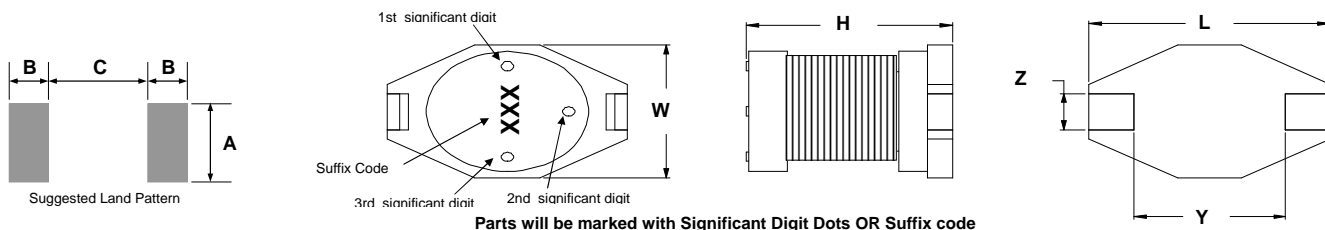

Series Number	Maximum Dimensions				Reference Dimensions				
	Units	L	W	H	Y	Z	A	B	C
MGDU3	inches	0.510"	0.370"	0.205"	0.300"	0.100"	0.110"	0.115"	0.290"
	[mm]	[12.95]	[9.40]	[5.21]	[7.62]	[2.54]	[2.79]	[2.92]	[7.37]

Features:

- High energy storage and low resistance
- Ideal for DC-DC step-up or step-down conversion.
- Reliable surface mounting, flat top for pick and place mounting
- Robust temperature deflection to prevent damage during solder reflow.
- Operating Temperature -40°C to +85°C.



Terminal Plating is Gold Flash over Ni
 260°C Maximum reflow temperature per J-STD020

Notes:

- Inductance measured at 100kHz, 100mVrms at 20°C.
- DCR (DC resistance) are maximum @ 20°C.
- Irms is the current applied to produce a typical 30°C temperature rise from nominal inductance.
- Isat is a maximum applied AC + DC current.
- Isat is the current applied to produce a typical 10% drop in nominal inductance
- Tolerance suffix of M = ±20%.

Schematic Diagram

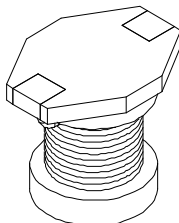
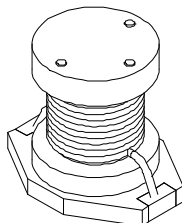
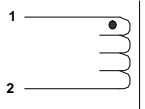

Contact CoEv for additional inductance values

MGDU3					
Lead Free Part Number	L μH	DCR	ISAT	IRMS	Tolerance Suffix
		W	A	A	
MGDU3-00004	1.0	0.0092	9.00	6.80	M
MGDU3-00005	1.5	0.0104	8.00	6.40	M
MGDU3-00006	2.2	0.0120	7.00	6.10	M
MGDU3-00007	3.3	0.0150	6.40	5.40	M
MGDU3-00003	4.7	0.0184	5.40	4.80	M
	5.6				
MGDU3-00008	6.8	0.0270	4.60	4.40	M
	8.0				
MGDU3-00009	10	0.0380	3.80	3.90	M
MGDU3-00010	15	0.0460	3.00	3.10	M
MGDU3-00011	22	0.0850	2.60	2.70	M
MGDU3-00012	33	0.1012	2.00	2.10	M
MGDU3-00013	47	0.1400	1.60	1.80	M
MGDU3-00014	68	0.2000	1.40	1.50	M
MGDU3-00015	100	0.2800	1.20	1.30	M
MGDU3-00016	150	0.4000	1.00	1.00	M
MGDU3-00017	220	0.6100	0.80	0.80	M
MGDU3-00018	330	1.0200	0.60	0.60	M
MGDU3-00019	470	1.2700	0.50	0.50	M
MGDU3-00020	680	2.0200	0.40	0.40	M
MGDU3-00021	1000	3.0000	0.30	0.30	M

Specifications subject to change

Call Toll Free: 888-978-2638 Website: www.tycopowercomponents.com

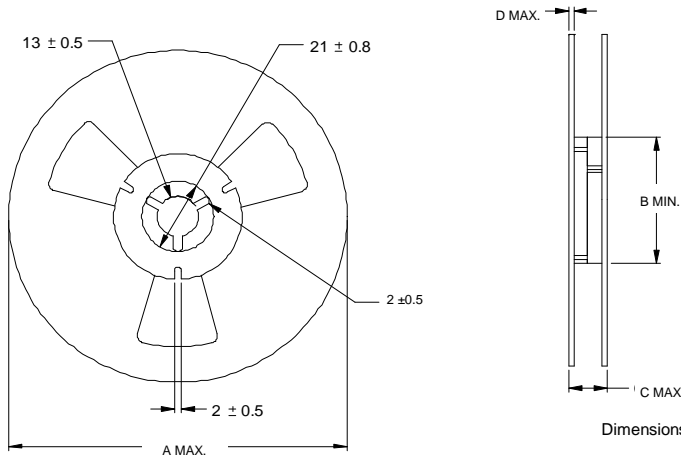

Dimensions are in millimeters unless specified.

Series Number	Reel dimensions				Reel Qty	Carton (Box) Qty.	Packaging Specification
	Units	A	B	C			
MGDU3	in.	14.17"	3.94"	0.88"	700	3500	90-0059
	[mm]	[360]	[100.0]	[22.4]			

PACKAGING NOTE: Only pressure sensitive cover tape is to be used.

CARRIER TAPE

START
TERMINAL
SIDE

PART

PART WILL EITHER HAVE 3 DIGIT CODE OR THREE DOT CODE PART SHOULD BE ORIENTED AS SHOWN WHERE "DDD" INDICATES THE DIRECTION OF PRINT FOR THE THREE DIGIT CODE, THE DOTS SHOULD BE ARRANGED AS SHOWN

COVER TAPE

FIGURE 1
CARRIER TAPE & PART

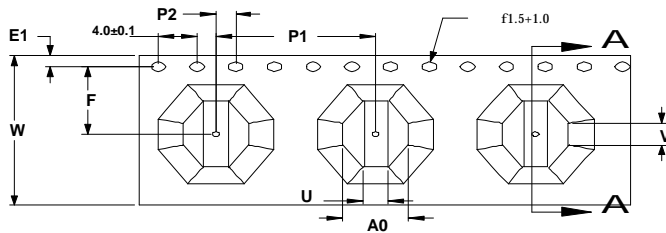

SECTION A-A

Series	A0 ± 0.1	U ± 0.1	V ± 0.1	P1 ± 0.1	P2 ± 0.1	W ± 0.3	F ± 0.1	E1 MIN.	B0 ± 0.1	K0 ± 0.05	T ± 0.05
MGDU3	9.50	3.90	4.00	12.00	2.00	24.00	11.50	1.75	13.10	5.30	0.35



Customer Packaging Specifications
For Print Distribution to Customers

Series	Revision
MGDU3	A0
Sheet 2 of 7	

Item	Specification	Test Method/Condition
Environmental		
Static Humidity	After exposure part remains within specified electrical parameters for L, Q and DCR.	Expose parts to an environment of +50°C with 90 to 95% R.H. for 100 hours. After exposure, allow parts to dry for 2 hours before measurements are taken.
Storage Life	After exposure part remains within specified electrical parameters for L, Q and DCR.	Subject parts to an environment of +50°C 90 to 100% R.H. for 46 to 50 hours. After exposure, allow parts to dry for 2 hours before measurements are taken.
Moisture Resistance	After exposure, part shall not have a shorted or open winding.	Per MIL-STD 202 Method 106, ten 24 hour cycles at +25°C to +65°C at 80 to 95% R.H. During any of the first 9 cycles, inductors are revolved from the chamber and exposed to -10°C for 3 hours. Allow parts to dry for 2 hours before measurements are taken.
Temperature Cycle	After exposure part remains within specified electrical parameters for L, Q and DCR.	10 cycles (Air to Air) 1 cycle shall consist of: 30 minutes exposure to +85°C 30 minutes exposure to -40°C Allow 20 minutes transition between extremes.
Temperature Shock	After exposure part remains within specified electrical parameters for L, Q and DCR.	10 cycles (Air to Air) 1 cycle shall consist of: 30 minutes exposure to -45°C 30 minutes exposure to +125°C 15 seconds maximum transition between temperatures
General		
Storage Temperature Range	-40°C to +85°C	
Operating Temperature Range	-40°C to +85°C	
Flammability	IEC 695-2-2	Withstands needle-flame test
Other		
Vibration	After exposure part remains within specified electrical parameters for L, Q and DCR.	Inductors shall be randomly vibrated per NAVMAT P9492 profile. Samples shall be subjected to 0.04G/Hz for a minimum of 15 minutes per axis, for each of the three axes.
Mechanical Shock	After exposure part remains within specified electrical parameters for L, Q and DCR.	Test per MIL-STD 202 method 213 test condition A, test mounted samples 3 axes, 6 times, totaling 18 shocks. (50Gs, 11ms, half-sine).
Solderability	Wetting shall cover 90% minimum of each termination	Dip pads in RMA flux, 63/37 solder (Sn/Pb) at 232°C for 5 seconds ±2 seconds.
Component Adhesion (Push Test)	4 pounds	Apply and measure force with a digital force gauge set.
Resistance to Solvent	No sign of degradation in appearance or marking detail.	Withstands 6 minutes of alcohol. Withstands 3 minutes forced spray Freon TMS
Load Life	After exposure, part shall not have a shorted or open winding.	Parts to be stored at 110°C for 1000 hours with rated current applied. Parts to be tested at: start, 500 and 1000 hours. Allow 2 hours at room temperature before testing.
		
For Print Distribution to Customers		Series
		MGDU3
		Revision
		A0
Sheet 3 of 7		