

Excellent Integrated System Limited

Stocking Distributor

Click to view price, real time Inventory, Delivery & Lifecycle Information:

[Fairchild Semiconductor](#)
[100LVEL16M](#)

For any questions, you can email us directly:

sales@integrated-circuit.com



January 2003
 Revised February 2003

100LVEL16 3.3V ECL Differential Receiver

General Description

The 100LVEL16 is a low voltage differential receiver that contains an internally supplied voltage source, V_{BB} . When used in a single ended input condition the unused input must be tied to V_{BB} . When operating in this mode use a 0.01 μ F capacitor to decouple V_{BB} and V_{CC} and also limit the current sinking or sourcing capability to 0.5mA. When V_{BB} is not used it should be left open.

With inputs open the differential Q outputs default LOW and \bar{Q} outputs default HIGH.

The 100 series is temperature compensated.

Features

- Typical propagation delay of 300 ps
- Typical I_{EE} of 17 mA
- Internal pull-down resistors on D
- Fairchild MSOP-8 package is a drop-in replacement to ON TSSOP-8
- Meets or exceeds JEDEC specification EIA/JESD78 IC latch-up test
- Moisture Sensitivity Level 1
- ESD Performance:
 - Human Body Model > 2000V
 - Machine Model > 150V

Ordering Code:

Order Number	Package Number	Product Code Top Mark	Package Description
100LVEL16M	M08A	KVL16	8-Lead Small Outline Integrated Circuit (SOIC), JEDEC MS-012, 0.150" Narrow
100LVEL16M8 (Preliminary)	MA08D	KV16	8-Lead Molded Small Outline Package (MSOP), JEDEC MO-187, 3.0mm Wide

Devices also available in Tape and Reel. Specify by appending suffix letter "X" to the ordering code.

Connection Diagram

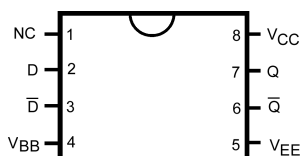

Top View

Logic Diagram

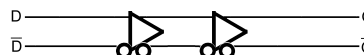

Pin Descriptions

Pin Name	Description
Q, \bar{Q}	ECL Data Outputs
D, \bar{D}	ECL Data Inputs
V_{BB}	Reference Voltage
V_{CC}	Positive Supply
V_{EE}	Negative Supply
NC	No Connect

100LVEL16

Absolute Maximum Ratings (Note 1)

PECL Supply Voltage (V_{CC}) $V_{EE} = 0V$	0.0V to +8.0V
NECL Supply Voltage (V_{EE}) $V_{CC} = 0V$	0.0V to -8.0V
PECL DC Input Voltage (V_I) $V_{EE} = 0V$	0.0V to +6.0V
NECL DC Input Voltage (V_I) $V_{CC} = 0V$	0.0V to -6.0V
DC Output Current (I_{OUT})	
Continuous	50 mA
Surge	100 mA
V_{BB} Sink/Source Current (I_{BB})	±0.5 mA
Storage Temperature (T_{STG})	-65°C to +150°C

Recommended Operating Conditions

PECL Power Supply ($V_{EE} = 0V$)	$V_{CC} = 3.0V$ to $3.8V$
NECL Power Supply ($V_{CC} = 0V$)	$V_{EE} = -3.8V$ to $-3.0V$
Free Air Operating Temperature (T_A)	-40°C to +85°C

Note 1: The "Absolute Maximum Ratings" are those values beyond which the safety of the device cannot be guaranteed. The device should not be operated at these limits. The parametric values defined in the Electrical Characteristics tables are not guaranteed at the absolute maximum rating. The "Recommended Operating Conditions" table will define the conditions for actual device operation.

LVPECL DC Electrical Characteristics $V_{CC} = 3.3V$; $V_{EE} = 0.0V$ (Note 2)

Symbol	Parameter	-40°C			25°C			85°C			Units
		Min	Typ	Max	Min	Typ	Max	Min	Typ	Max	
I_{EE}	Power Supply Current		17	23		17	23		18	24	mA
V_{OH}	Output HIGH Voltage (Note 3)	2215	2295	2420	2275	2345	2420	2275	2345	2420	mV
V_{OL}	Output LOW Voltage (Note 3)	1470	1605	1745	1490	1595	1680	1490	1595	1680	mV
V_{IH}	Input HIGH Voltage (Single Ended)	2135		2420	2135		2420	2135		2420	mV
V_{IL}	Input LOW Voltage (Single Ended)	1490		1825	1490		1825	1490		1825	mV
V_{BB}	Output Voltage Reference	1.92		2.04	1.92		2.04	1.92		2.04	V
V_{IHCMR}	Input HIGH Voltage Common Mode Range (Differential) (Note 4)										V
	$V_{PP} < 500mV$	1.2		2.9	1.1		2.9	1.1		2.9	
	$V_{PP} \geq 500mV$	1.5		2.9	1.4		2.9	1.4		2.9	
I_{IH}	Input HIGH Current (Note 5)			150			150			150	μA
I_{IL}	Input LOW Current (Note 5)	D	0.5		0.5			0.5			μA
		\bar{D}	-600		-600			-600			

Note 2: Input and output parameters vary 1 to 1 with V_{CC} . V_{EE} can vary ±0.3V.

Note 3: Outputs are terminated through a 50Ω Resistor to $V_{CC} - 2.0V$.

Note 4: V_{IHCMR} minimum varies 1 to 1 with V_{EE} . V_{IHCMR} maximum varies 1 to 1 with V_{CC} . The V_{IHCMR} range is referenced to the most positive side of the differential input signal. Normal operation is obtained if the HIGH level falls within the specified range and the peak-to-peak voltage lies between V_{PPMIN} and 1V.

Note 5: Absolute value of the input HIGH and LOW current should not exceed the absolute value of the stated Min or Max specification.

Note: Devices are designed to meet the DC specifications after thermal equilibrium has been established. Circuit is tested with air flow greater than 500LFPM maintained.

LVNECL DC Electrical Characteristics $V_{CC} = 0.0V$; $V_{EE} = -3.3V$ (Note 6)											
Symbol	Parameter	-40°C			25°C			85°C			Units
		Min	Typ	Max	Min	Typ	Max	Min	Typ	Max	
I_{EE}	Power Supply Current		17	23		17	23		18	24	mA
V_{OH}	Output HIGH Voltage (Note 7)	-1085	-1005	-880	-1025	-955	-880	-1025	-955	-880	mV
V_{OL}	Output LOW Voltage (Note 7)	-1830	-1695	-1555	-1810	-1705	-1620	-1810	-1705	-1620	mV
V_{IH}	Input HIGH Voltage (Single Ended)	-1165		-880	-1165		-880	-1165		-880	mV
V_{IL}	Input LOW Voltage (Single Ended)	-1810		-1475	-1810		-1475	-1810		-1475	mV
V_{BB}	Output Voltage Reference	-1.38		-1.26	-1.38		-1.26	-1.38		-1.26	V
V_{IHCMR}	Input HIGH Voltage Common Mode Range (Differential) (Note 8)										V
	$V_{PP} < 500mV$	-2.5		-0.4	-2.5		-0.4	-2.5		-0.4	
	$V_{PP} \geq 500mV$	-1.8		-0.4	-1.9		-0.4	-1.9		-0.4	
I_{IH}	Input HIGH Current			150			150			150	μA
I_{IL}	Input LOW Current	D	0.5		0.5			0.5			μA
	\bar{D}		-600		-600			-600			μA

Note 6: Input and output parameters vary 1 to 1 with V_{CC} . V_{EE} can vary $\pm 0.3V$.

Note 7: Outputs are terminated through a 50 Ω Resistor to $V_{CC} - 2.0V$.

Note 8: V_{IHCMR} minimum varies 1 to 1 with V_{EE} . V_{IHCMR} maximum varies 1-to-1 with V_{CC} . The V_{IHCMR} range is referenced to the most positive side of the differential input signal. Normal operation is obtained if the HIGH level falls within the specified range and the peak-to-peak voltage lies between V_{PPMIN} and 1V.

Note 9: Absolute value of the input HIGH and LOW current should not exceed the absolute value of the stated Min or Max specification.

Note: Devices are designed to meet the DC specifications after thermal equilibrium has been established. Circuit is tested with air flow greater than 500LFPM maintained.

100LVEL16 AC Electrical Characteristics $V_{CC} = 3.3V$; $V_{EE} = 0.0V$ or $V_{CC} = 0.0V$; $V_{EE} = -3.3V$ (Note 10) (Note 11)												
Symbol	Parameter	-40°C			25°C			85°C			Units	Figure Number
		Min	Typ	Max	Min	Typ	Max	Min	Typ	Max		
f_{MAX}	Maximum Toggle Frequency		TBD		TBD		TBD		TBD		GHz	
t_{PLH} , t_{PHL}	Propagation Delay to Output (Diff) (SE)	150	275	400	225	300	375	240	315	390	ps	Figures 1, 3
		100	275	450	175	300	425	190	315	440		
t_{SKEW}	Duty Cycle Skew (Note 12)		5	30		5	20		5	20	ps	
t_{JITTER}	Cycle-to-Cycle Jitter		TBD		TBD		TBD		TBD		ps	
V_{PP}	Input Swing	150		1000	150		1000	150		1000	mV	Figure 1
t_r , t_f	Output Rise Times Q (20% to 80%)	120	220	320	120	220	320	120	220	320	ps	Figure 2

Note 10: V_{EE} can vary $\pm 0.3V$.

Note 11: Measured using a 750 mV input swing centered at $V_{CC} - 1.32V$; 50% duty cycle clock source; $t_r = t_f = 250$ ps (20% - 80%) at $f_{IN} = 1$ MHz. All loading with 50 Ω to $V_{CC} - 2.0V$.

Note 12: Duty cycle skew is the difference between a t_{PLH} and t_{PHL} propagation delay through a device under identical conditions.

100LVEL16

Switching Waveforms

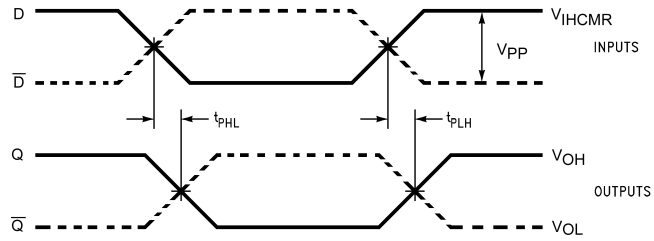

FIGURE 1. Differential to Differential Propagation Delay

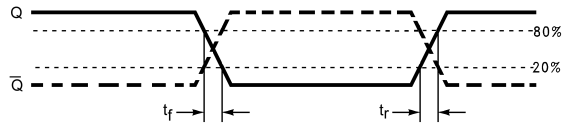

FIGURE 2. Differential Output Edge Rates

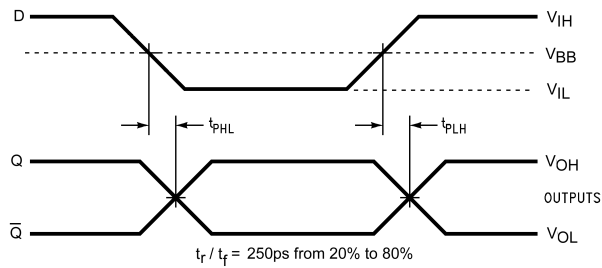
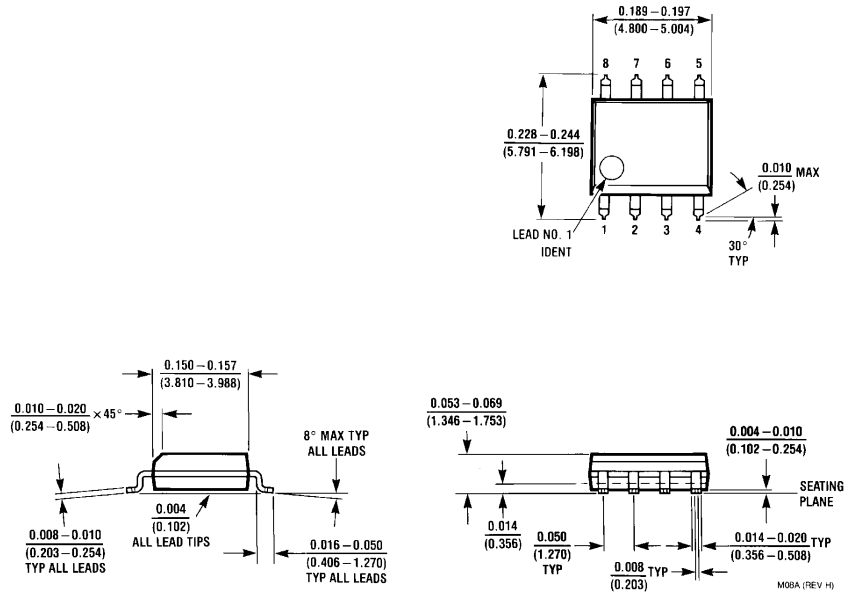

FIGURE 3. Single Ended to Differential Propagation Delay

100LVEL16

Physical Dimensions inches (millimeters) unless otherwise noted



**8-Lead Small Outline Integrated Circuit (SOIC), JEDEC MS-012, 0.150" Narrow
 Package Number M08A**

100LVEL16 3.3V ECL Differential Receiver

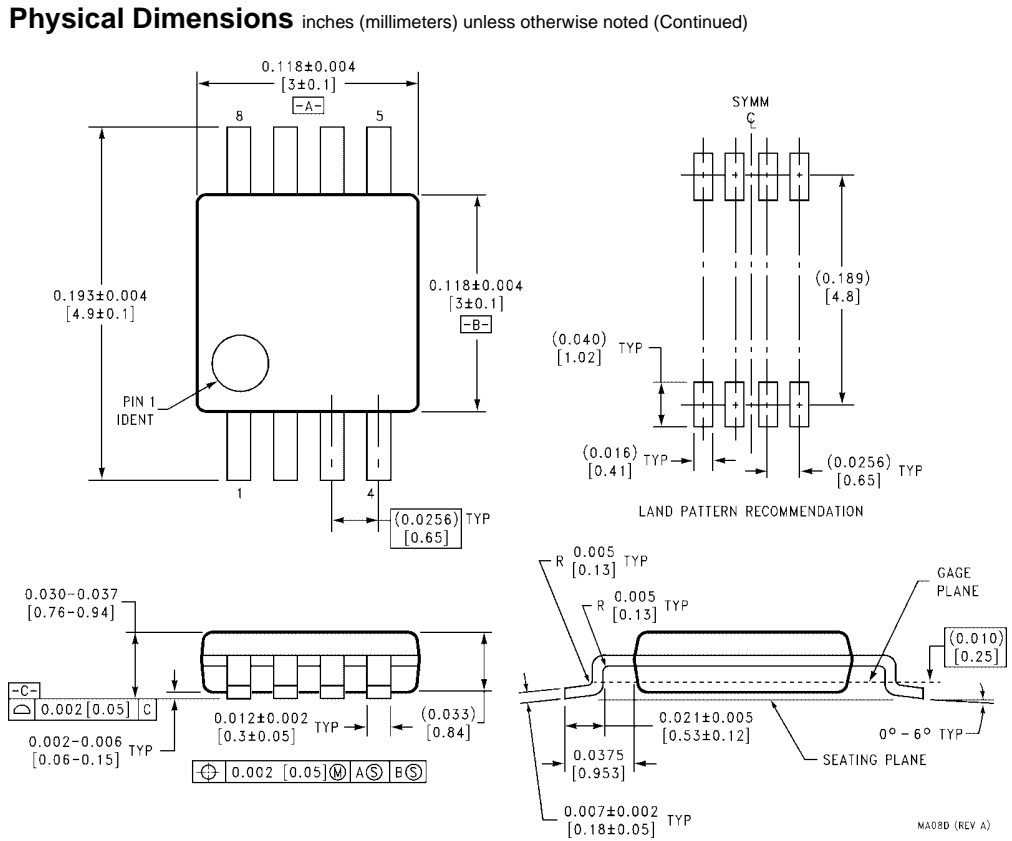

**8-Lead Molded Small Outline Package (MSOP), JEDEC MO-187, 3.0mm Wide
Package Number MA08D**

Fairchild does not assume any responsibility for use of any circuitry described, no circuit patent licenses are implied and Fairchild reserves the right at any time without notice to change said circuitry and specifications.

LIFE SUPPORT POLICY

FAIRCHILD'S PRODUCTS ARE NOT AUTHORIZED FOR USE AS CRITICAL COMPONENTS IN LIFE SUPPORT DEVICES OR SYSTEMS WITHOUT THE EXPRESS WRITTEN APPROVAL OF THE PRESIDENT OF FAIRCHILD SEMICONDUCTOR CORPORATION. As used herein:

1. Life support devices or systems are devices or systems which, (a) are intended for surgical implant into the body, or (b) support or sustain life, and (c) whose failure to perform when properly used in accordance with instructions for use provided in the labeling, can be reasonably expected to result in a significant injury to the user.
2. A critical component in any component of a life support device or system whose failure to perform can be reasonably expected to cause the failure of the life support device or system, or to affect its safety or effectiveness.

www.fairchildsemi.com