

## Excellent Integrated System Limited

Stocking Distributor

Click to view price, real time Inventory, Delivery & Lifecycle Information:

[Fairchild Semiconductor](#)  
[74VHCT573ASJX](#)

For any questions, you can email us directly:  
[sales@integrated-circuit.com](mailto:sales@integrated-circuit.com)



## 74VHCT573A Octal D-Type Latch with 3-STATE Outputs

### Features

- High speed:  $t_{PD} = 7.7\text{ns}$  (Typ.) at  $T_A = 25^\circ\text{C}$
- High Noise Immunity:  $V_{IH} = 2.0\text{V}$ ,  $V_{IL} = 0.8\text{V}$
- Power Down Protection is provided on all inputs and outputs
- Low Noise:  $V_{OLP} = 1.6\text{V}$  (Max.)
- Low Power Dissipation:  $I_{CC} = 4\mu\text{A}$  (Max.) @  $T_A = 25^\circ\text{C}$
- Pin and function compatible with 74HCT573

### General Description

The VHCT573A is an advanced high speed CMOS octal latch with 3-STATE output fabricated with silicon gate CMOS technology. It achieves the high speed operation similar to equivalent Bipolar Schottky TTL while maintaining the CMOS low power dissipation. This 8-bit D-type latch is controlled by a Latch Enable input (LE) and an Output Enable input ( $\overline{OE}$ ). When the  $\overline{OE}$  input is HIGH, the eight outputs are in a high impedance state.

Protection circuits ensure that 0V to 7V can be applied to the input and output<sup>(1)</sup> pins without regard to the supply voltage. This device can be used to interface 3V to 5V systems and two supply systems such as battery back up. This circuit prevents device destruction due to mismatched supply and input voltages.

#### Note:

1. Outputs in OFF-State

### Ordering Information

Order Number	Package Number	Package Description
74VHCT573AM	M20B	20-Lead Small Outline Integrated Circuit (SOIC), JEDEC MS-013, 0.300" Wide
74VHCT573ASJ	M20D	20-Lead Small Outline Package (SOP), EIAJ TYPE II, 5.3mm Wide
74VHCT573AMTC	MTC20	20-Lead Thin Shrink Small Outline Package (TSSOP), JEDEC MO-153, 4.4mm Wide

Surface mount packages are also available on Tape and Reel. Specify by appending the suffix letter "X" to the ordering number. Pb-Free package per JEDEC J-STD-020B.

### Connection Diagram

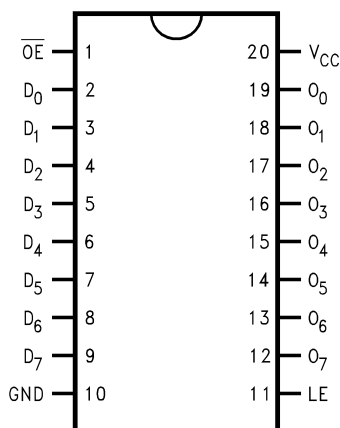

### Pin Description

Pin Names	Description
$D_0$ – $D_7$	Data Inputs
LE	Latch Enable Input
$\overline{OE}$	3-STATE Output Enable Input
$O_0$ – $O_7$	3-STATE Outputs

### Logic Symbol

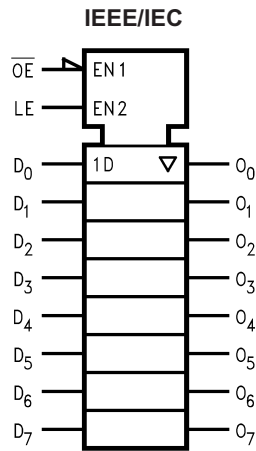

### Functional Description

The VHCT573A contains eight D-type latches with 3-STATE output buffers. When the Latch Enable (LE) input is HIGH, data on the  $D_n$  inputs enters the latches. In this condition the latches are transparent, i.e., a latch output will change state each time its D input changes. When LE is LOW the latches store the information that was present on the D inputs, a setup time preceding the HIGH-to-LOW transition of LE. The 3-STATE buffers are controlled by the Output Enable ( $\overline{OE}$ ) input. When  $\overline{OE}$  is LOW, the buffers are enabled. When  $\overline{OE}$  is HIGH the buffers are in the high impedance mode, but, this does not interfere with entering new data into the latches.

### Truth Table

Inputs			Outputs
$\overline{OE}$	LE	D	$O_n$
L	H	H	H
L	H	L	L
L	L	X	$O_0$
H	X	X	Z

H = HIGH Voltage Level

L = LOW Voltage Level

X = Immaterial

Z = High Impedance

### Logic Diagram

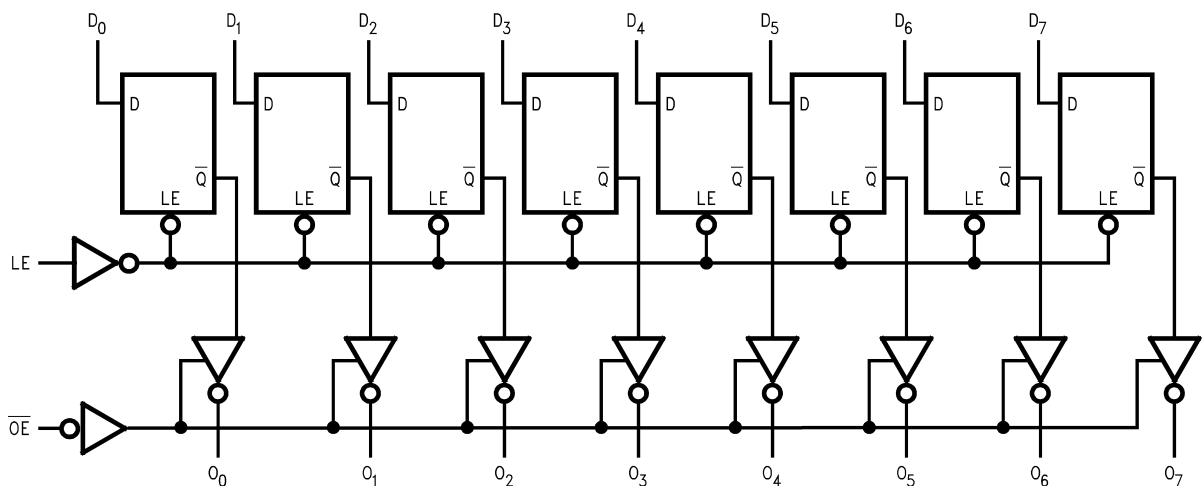

Please note that this diagram is provided only for the understanding of logic operations and should not be used to estimate propagation delays.

### Absolute Maximum Ratings

Stresses exceeding the absolute maximum ratings may damage the device. The device may not function or be operable above the recommended operating conditions and stressing the parts to these levels is not recommended. In addition, extended exposure to stresses above the recommended operating conditions may affect device reliability. The absolute maximum ratings are stress ratings only.

Symbol	Parameter	Rating
$V_{CC}$	Supply Voltage	-0.5V to +7.0V
$V_{IN}$	DC Input Voltage	-0.5V to +7.0V
$V_{OUT}$	DC Output Voltage Note 2 Note 3	-0.5V to $V_{CC} + 0.5V$ -0.5V to +7.0V
$I_{IK}$	Input Diode Current	-20mA
$I_{OK}$	Output Diode Current <sup>(4)</sup>	±20mA
$I_{OUT}$	DC Output Current	±25mA
$I_{CC}$	DC $V_{CC}$ /GND Current	±75mA
$T_{STG}$	Storage Temperature	-65°C to +150°C
$T_L$	Lead Temperature (Soldering, 10 seconds)	260°C

### Recommended Operating Conditions<sup>(5)</sup>

The Recommended Operating Conditions table defines the conditions for actual device operation. Recommended operating conditions are specified to ensure optimal performance to the datasheet specifications. Fairchild does not recommend exceeding them or designing to absolute maximum ratings.

Symbol	Parameter	Rating
$V_{CC}$	Supply Voltage	4.5V to +5.5V
$V_{IN}$	Input Voltage	0V to +5.5V
$V_{OUT}$	Output Voltage Note 2 Note 3	0V to $V_{CC}$ 0V to 5.5V
$T_{OPR}$	Operating Temperature	-40°C to +85°C
$t_r, t_f$	Input Rise and Fall Time, $V_{CC} = 5.0V \pm 0.5V$	0ns/V ~ 20ns/V

**Notes:**

2. HIGH or LOW state.  $I_{OUT}$  absolute maximum rating must be observed.
3. When outputs are in OFF-State or when  $V_{CC} = 0V$ .
4.  $V_{OUT} < GND$ ,  $V_{OUT} > V_{CC}$  (Outputs Active).
5. Unused inputs must be held HIGH or LOW. They may not float.

### DC Electrical Characteristics

Symbol	Parameter	V <sub>CC</sub> (V)	Conditions	T <sub>A</sub> = 25°C			T <sub>A</sub> = -40°C to +85°C		Units
				Min.	Typ.	Max.	Min.	Max.	
V <sub>IH</sub>	HIGH Level Input Voltage	4.5		2.0			2.0		V
		5.5		2.0			2.0		
V <sub>IL</sub>	LOW Level Input Voltage	4.5				0.8		0.8	V
		5.5				0.8		0.8	
V <sub>OH</sub>	HIGH Level Output Voltage	4.5	V <sub>IN</sub> = V <sub>IH</sub> or V <sub>IL</sub>	I <sub>OH</sub> = -50μA	4.40	4.50		4.40	V
				I <sub>OH</sub> = -8mA	3.94			3.80	
V <sub>OL</sub>	LOW Level Output Voltage	4.5	V <sub>IN</sub> = V <sub>IH</sub> or V <sub>IL</sub>	I <sub>OL</sub> = 50μA		0.0	0.1	0.1	V
				I <sub>OL</sub> = 8mA			0.36	0.44	
I <sub>OZ</sub>	3-STATE Output Off-State Current	5.5	V <sub>IN</sub> = V <sub>IH</sub> or V <sub>IL</sub> , V <sub>OUT</sub> = V <sub>CC</sub> or GND				±0.25	±2.5	μA
I <sub>IN</sub>	Input Leakage Current	0-5.5	V <sub>IN</sub> = 5.5V or GND				±0.1	±1.0	μA
I <sub>CC</sub>	Quiescent Supply Current	5.5	V <sub>IN</sub> = V <sub>CC</sub> or GND				4.0	40.0	μA
I <sub>CCT</sub>	Maximum I <sub>CC</sub> /Input	5.5	V <sub>IN</sub> = 3.4V, Other Inputs = V <sub>CC</sub> or GND				1.35	1.50	mA
I <sub>OFF</sub>	Output Leakage Current (Power Down State)	0.0	V <sub>OUT</sub> = 5.5V				0.5	5.0	μA

### Noise Characteristics

Symbol	Parameter	V <sub>CC</sub> (V)	Conditions	T <sub>A</sub> = 25°C		Units
				Typ.	Limits	
V <sub>OLP</sub> <sup>(6)</sup>	Quiet Output Maximum Dynamic V <sub>OL</sub>	5.0	C <sub>L</sub> = 50pF	1.2	1.6	V
V <sub>OLV</sub> <sup>(6)</sup>	Quiet Output Minimum Dynamic V <sub>OL</sub>	5.0	C <sub>L</sub> = 50pF	-1.2	-1.6	V
V <sub>IHD</sub> <sup>(6)</sup>	Minimum HIGH Level Dynamic Input Voltage	5.0	C <sub>L</sub> = 50pF		2.0	V
V <sub>ILD</sub> <sup>(6)</sup>	Maximum LOW Level Dynamic Input Voltage	5.0	C <sub>L</sub> = 50pF		0.8	V

**Note:**

6. Parameter guaranteed by design.

### AC Electrical Characteristics

Symbol	Parameter	V <sub>CC</sub> (V)	Conditions	T <sub>A</sub> = +25°C			T <sub>A</sub> = -40°C to +85°C		Units
				Min.	Typ.	Max.	Min.	Max.	
t <sub>PLH</sub> , t <sub>PHL</sub>	Propagation Delay Time (LE to O <sub>n</sub> )	5.0 ± 0.5		C <sub>L</sub> = 15pF	7.7	12.3	1.0	13.5	ns
				C <sub>L</sub> = 50pF	8.5	13.3	1.0	14.5	
t <sub>PLH</sub> , t <sub>PHL</sub>	Propagation Delay Time (D to O <sub>n</sub> )	5.0 ± 0.5		C <sub>L</sub> = 15pF	5.1	8.5	1.0	9.5	ns
				C <sub>L</sub> = 50pF	5.9	9.5	1.0	10.5	
t <sub>PZL</sub> , t <sub>PZH</sub>	3-STATE Output Enable Time	5.0 ± 0.5	R <sub>L</sub> = 1kΩ	C <sub>L</sub> = 15pF	6.3	10.9	1.0	12.5	ns
				C <sub>L</sub> = 50pF	7.1	11.9	1.0	13.5	
t <sub>PLZ</sub> , t <sub>PHZ</sub>	3-STATE Output Disable Time	5.0 ± 0.5	R <sub>L</sub> = 1kΩ	C <sub>L</sub> = 50pF	8.8	11.2	1.0	12.0	ns
t <sub>OSLH</sub> , t <sub>OSHL</sub>	Output to Output Skew	5.0 ± 0.5	(7)			1.0		1.0	ns
C <sub>IN</sub>	Input Capacitance		V <sub>CC</sub> = Open		4	10		10	pF
C <sub>OUT</sub>	Output Capacitance		V <sub>CC</sub> = 5.0V		6				pF
C <sub>PD</sub>	Power Dissipation Capacitance		(8)		25				pF

**Notes:**

- 7. Parameter guaranteed by design. t<sub>OSLH</sub> = |t<sub>PLH</sub> max - t<sub>PLH</sub> min|; t<sub>OSHL</sub> = |t<sub>PHL</sub> max - t<sub>PHL</sub> min|
- 8. C<sub>PD</sub> is defined as the value of the internal equivalent capacitance which is calculated from the operating current consumption without load. Average operating current can be obtained by the equation:  
 $I_{CC} (Opr.) = C_{PD} \cdot V_{CC} \cdot f_{IN} + I_{CC} / 8$  (per F/F). The total C<sub>PD</sub> when n pcs. of the Latch operates can be calculated by the equation: C<sub>PD</sub>(total) = 14 + 13n.

### AC Operating Requirements

Symbol	Parameter	V <sub>CC</sub> (V)	T <sub>A</sub> = +25°C			T <sub>A</sub> = -40°C to +85°C		Units
			Min.	Typ.	Max.	Min.	Max.	
t <sub>W(H)</sub>	Minimum Pulse Width (LE)	5.0 ± 0.5	6.5			8.5		ns
t <sub>S</sub>	Minimum Set-Up Time	5.0 ± 0.5	1.5			1.5		ns
t <sub>H</sub>	Minimum Hold Time	5.0 ± 0.5	3.5			3.5		ns

### Physical Dimensions

Dimensions are in millimeters unless otherwise noted.

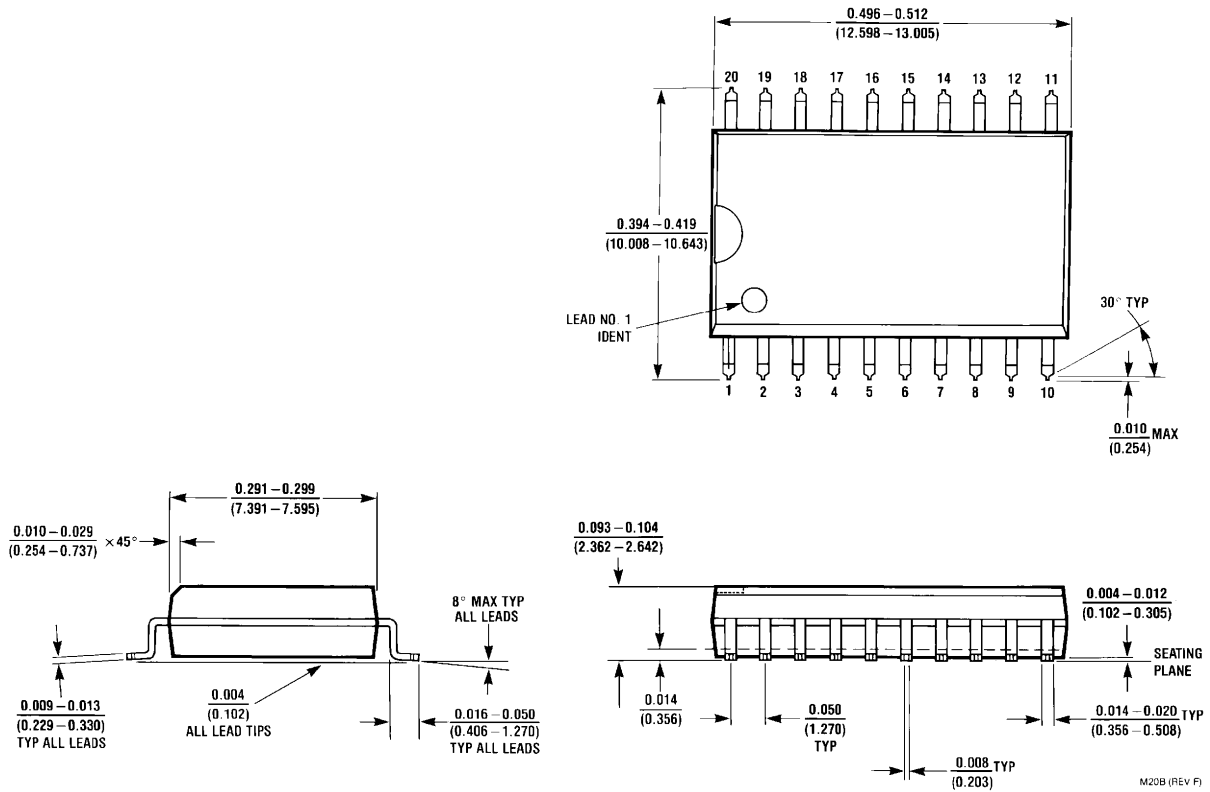
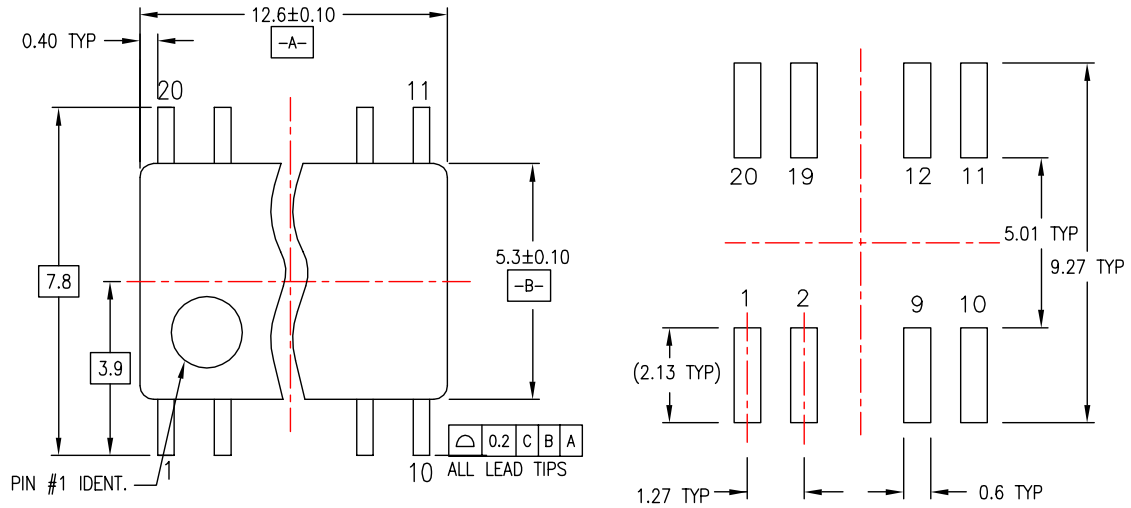

Figure 1. 20-Lead Small Outline Integrated Circuit (SOIC), JEDEC MS-013, 0.300" Wide Package Number M20B

**Physical Dimensions (Continued)**

Dimensions are in millimeters unless otherwise noted.



LAND PATTERN RECOMMENDATION

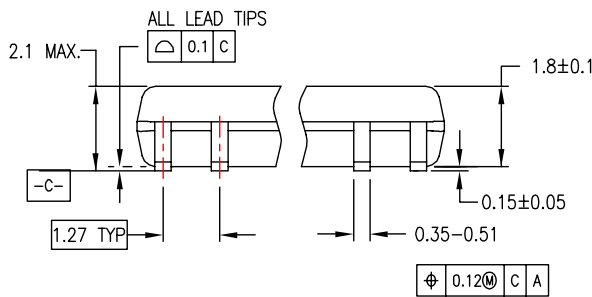

DIMENSIONS ARE IN MILLIMETERS

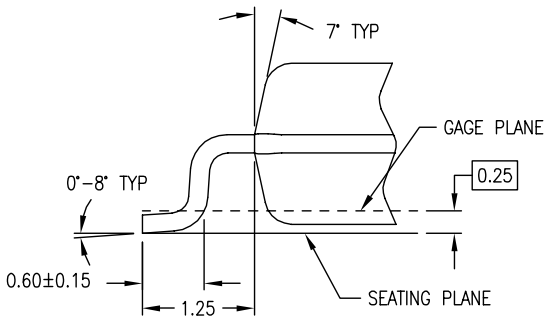
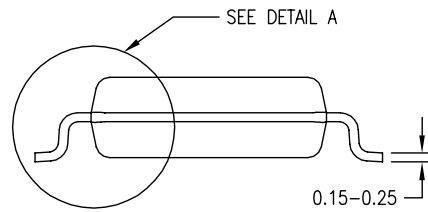

DETAIL A

NOTES:

- A. CONFORMS TO EIAJ EDR-7320 REGISTRATION, ESTABLISHED IN DECEMBER, 1998.
- B. DIMENSIONS ARE IN MILLIMETERS.
- C. DIMENSIONS ARE EXCLUSIVE OF BURRS, MOLD FLASH, AND TIE BAR EXTRUSIONS.

M20DREVC

**Figure 2. 20-Lead Small Outline Package (SOP), EIAJ TYPE II, 5.3mm Wide Package Number M20D**



**Physical Dimensions (Continued)**

Dimensions are in millimeters unless otherwise noted.

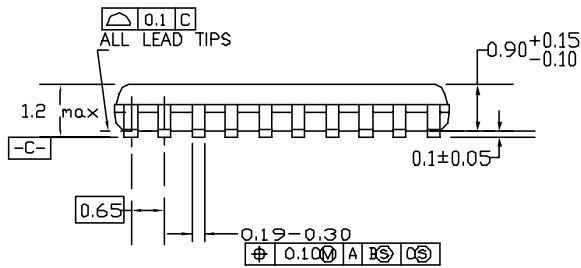
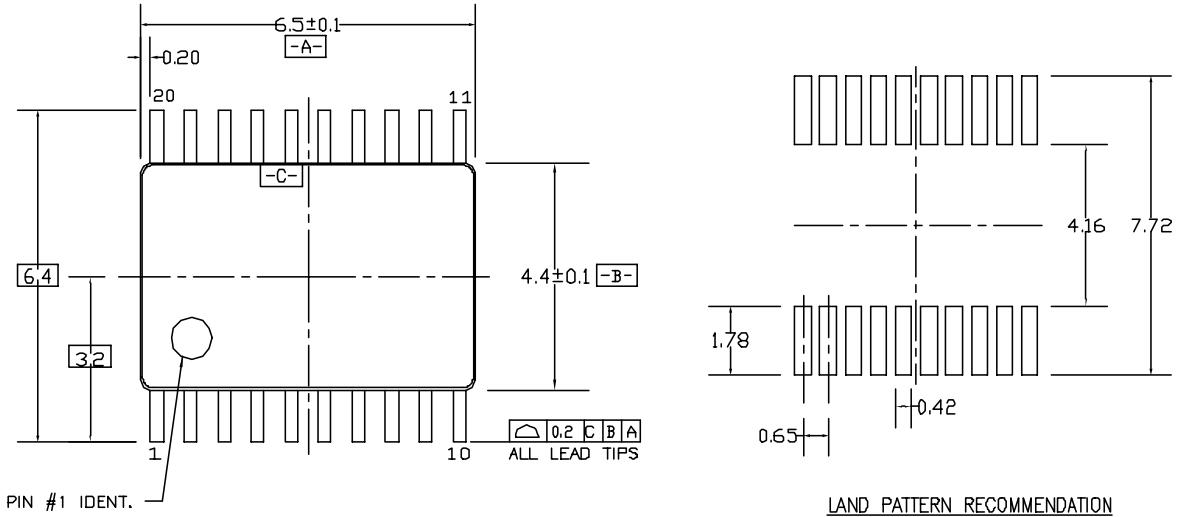

DIMENSIONS ARE IN MILLIMETERS

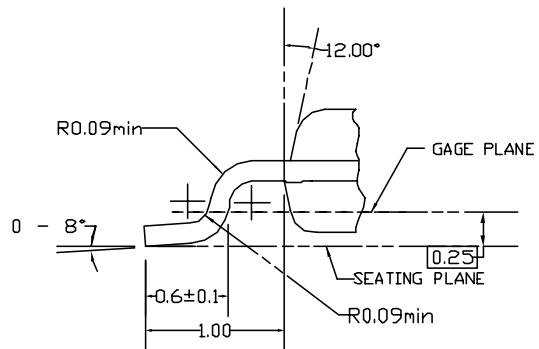
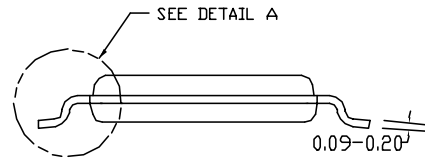

DETAIL A

NOTES:

- A. CONFORMS TO JEDEC REGISTRATION MO-153, VARIATION AC, REF NOTE 6, DATE 7/93.
- B. DIMENSIONS ARE IN MILLIMETERS.
- C. DIMENSIONS ARE EXCLUSIVE OF BURRS, MOLDS FLASH, AND THE BAR EXTRUSIONS.
- D. DIMENSIONS AND TOLERANCES PER ANSI Y14.5M, 1982.

MTC20REV D1

**Figure 3. 20-Lead Thin Shrink Small Outline Package (TSSOP), JEDEC MO-153, 4.4mm Wide Package Number MTC20**



### TRADEMARKS

The following are registered and unregistered trademarks Fairchild Semiconductor owns or is authorized to use and is not intended to be an exhaustive list of all such trademarks.

ACE <sup>x</sup>	HiSeC <sup>TM</sup>	Power-SPM <sup>TM</sup>	TinyBuck <sup>TM</sup>
Across the board. Around the world. <sup>TM</sup>	<i>i-Lo</i> <sup>TM</sup>	PowerTrench <sup>®</sup>	TinyLogic <sup>®</sup>
ActiveArray <sup>TM</sup>	ImpliedDisconnect <sup>TM</sup>	Programmable Active Droop <sup>TM</sup>	TINYOPTO <sup>TM</sup>
Bottomless <sup>TM</sup>	IntelliMAX <sup>TM</sup>	QFET <sup>®</sup>	TinyPower <sup>TM</sup>
Build it Now <sup>TM</sup>	ISOPLANAR <sup>TM</sup>	QS <sup>TM</sup>	TinyWire <sup>TM</sup>
CoolFET <sup>TM</sup>	MICROCOUPLER <sup>TM</sup>	QT Optoelectronics <sup>TM</sup>	TruTranslation <sup>TM</sup>
CorePLUS <sup>TM</sup>	MicroPak <sup>TM</sup>	Quiet Series <sup>TM</sup>	μSerDes <sup>TM</sup>
CROSSVOLT <sup>TM</sup>	MICROWIRE <sup>TM</sup>	RapidConfigure <sup>TM</sup>	UHC <sup>®</sup>
CTL <sup>TM</sup>	Motion-SPM <sup>TM</sup>	RapidConnect <sup>TM</sup>	UniFET <sup>TM</sup>
Current Transfer Logic <sup>TM</sup>	MSX <sup>TM</sup>	ScalarPump <sup>TM</sup>	VCX <sup>TM</sup>
DOME <sup>TM</sup>	MSXPro <sup>TM</sup>	SMART START <sup>TM</sup>	Wire <sup>TM</sup>
E <sup>2</sup> CMOS <sup>TM</sup>	OCX <sup>TM</sup>	SPM <sup>®</sup>	
EcoSPARK <sup>®</sup>	OCXPro <sup>TM</sup>	STEALTH <sup>TM</sup>	
EnSigna <sup>TM</sup>	OPTOLOGIC <sup>®</sup>	SuperFET <sup>TM</sup>	
FACT Quiet Series <sup>TM</sup>	OPTOPLANAR <sup>®</sup>	SuperSOT <sup>TM</sup> -3	
FACT <sup>®</sup>	PACMAN <sup>TM</sup>	SuperSOT <sup>TM</sup> -6	
FAST <sup>®</sup>	PDP-SPM <sup>TM</sup>	SuperSOT <sup>TM</sup> -8	
FAST <sup>r</sup> <sup>TM</sup>	POP <sup>TM</sup>	SyncFET <sup>TM</sup>	
FPS <sup>TM</sup>	Power220 <sup>®</sup>	TCM <sup>TM</sup>	
FRFET <sup>®</sup>	Power247 <sup>®</sup>	The Power Franchise <sup>®</sup>	
GlobalOptoisolator <sup>TM</sup>	PowerEdge <sup>TM</sup>	 <sup>TM</sup>	
GTO <sup>TM</sup>	PowerSaver <sup>TM</sup>	TinyBoost <sup>TM</sup>	

### DISCLAIMER

FAIRCHILD SEMICONDUCTOR RESERVES THE RIGHT TO MAKE CHANGES WITHOUT FURTHER NOTICE TO ANY PRODUCTS HEREIN TO IMPROVE RELIABILITY, FUNCTION, OR DESIGN. FAIRCHILD DOES NOT ASSUME ANY LIABILITY ARISING OUT OF THE APPLICATION OR USE OF ANY PRODUCT OR CIRCUIT DESCRIBED HEREIN; NEITHER DOES IT CONVEY ANY LICENSE UNDER ITS PATENT RIGHTS, NOR THE RIGHTS OF OTHERS. THESE SPECIFICATIONS DO NOT EXPAND THE TERMS OF FAIRCHILD'S WORLDWIDE TERMS AND CONDITIONS, SPECIFICALLY THE WARRANTY THEREIN, WHICH COVERS THESE PRODUCTS.

### LIFE SUPPORT POLICY

FAIRCHILD'S PRODUCTS ARE NOT AUTHORIZED FOR USE AS CRITICAL COMPONENTS IN LIFE SUPPORT DEVICES OR SYSTEMS WITHOUT THE EXPRESS WRITTEN APPROVAL OF FAIRCHILD SEMICONDUCTOR CORPORATION.

As used herein:

1. Life support devices or systems are devices or systems which, (a) are intended for surgical implant into the body or (b) support or sustain life, and (c) whose failure to perform when properly used in accordance with instructions for use provided in the labeling, can be reasonably expected to result in a significant injury of the user.
2. A critical component in any component of a life support, device, or system whose failure to perform can be reasonably expected to cause the failure of the life support device or system, or to affect its safety or effectiveness.

### PRODUCT STATUS DEFINITIONS

#### Definition of Terms

Datasheet Identification	Product Status	Definition
Advance Information	Formative or In Design	This datasheet contains the design specifications for product development. Specifications may change in any manner without notice.
Preliminary	First Production	This datasheet contains preliminary data; supplementary data will be published at a later date. Fairchild Semiconductor reserves the right to make changes at any time without notice to improve design.
No Identification Needed	Full Production	This datasheet contains final specifications. Fairchild Semiconductor reserves the right to make changes at any time without notice to improve design.
Obsolete	Not In Production	This datasheet contains specifications on a product that has been discontinued by Fairchild Semiconductor. The datasheet is printed for reference information only.

Rev. I27