

Excellent Integrated System Limited

Stocking Distributor

Click to view price, real time Inventory, Delivery & Lifecycle Information:

[Fairchild Semiconductor](#)
[74VHC4040N](#)

For any questions, you can email us directly:

sales@integrated-circuit.com



74VHC4040

12-Stage Binary Counter

Features

- High speed; $f_{MAX} = 210\text{MHz}$ at $V_{CC} = 5\text{V}$
- Low power dissipation: $I_{CC} = 4\mu\text{A}$ (Max.) at $T_A = 25^\circ\text{C}$
- High noise immunity: $V_{NIH} = V_{NIL} = 28\% V_{CC}$ (Min.)
- Power down protection is provided on all inputs
- Wide operating voltage range: V_{CC} (Opr.) = $2\text{V} - 5.5\text{V}$
- Low noise: $V_{OLP} = 0.8\text{V}$ (Max.)
- Pin and function compatible with 74HC4040

General Description

The VHC4040 is an advanced high-speed CMOS device fabricated with silicon gate CMOS technology. It achieves the high-speed operation similar to equivalent Bipolar Schottky TTL while maintaining the CMOS low power dissipation. The VHC4040 is a 12-stage counter which increments on the negative edge of the input clock and all outputs are reset to a low level by applying a logical high on the reset input. An input protection circuit insures that 0V to 7V can be applied to the inputs without regard to the supply voltage. This device can be used to interface 5V to 3V systems and two supply systems such as battery backup. This circuit prevents device destruction due to mismatched supply and input voltages.

Ordering Information

Order Number	Package Number	Package Description
74VHC4040M	M16A	16-Lead Small Outline Integrated Circuit (SOIC), JEDEC MS-012, 0.150" Narrow
74VHC4040MTC	MTC16	16-Lead Thin Shrink Small Outline Package (TSSOP), JEDEC MO-153, 4.4mm Wide

Surface mount packages are also available on Tape and Reel. Specify by appending the suffix letter "X" to the ordering number.

Connection Diagram

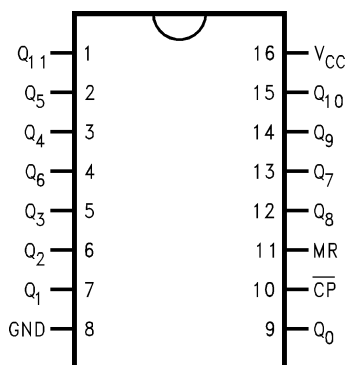

Pin Descriptions

Pin Names	Description
$Q_0 - Q_{11}$	Flip-Flop Outputs
CP	Negative Edged Triggered Clock
MR	Master Reset

Logic Symbols

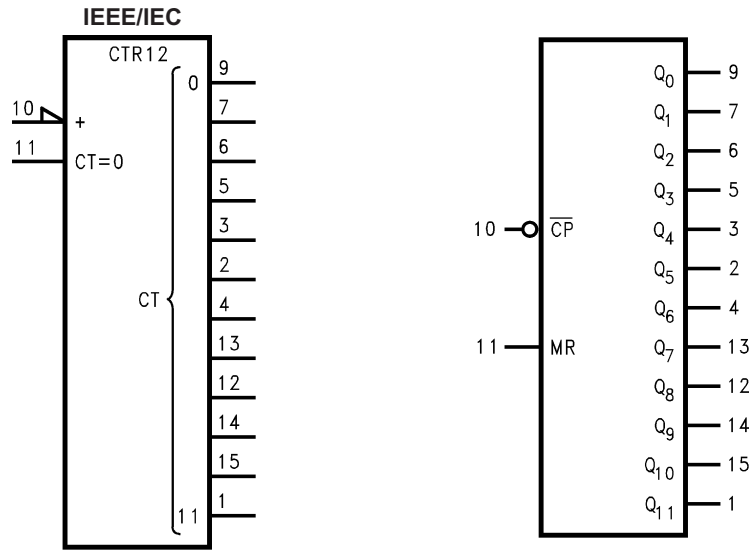

Logic Diagram

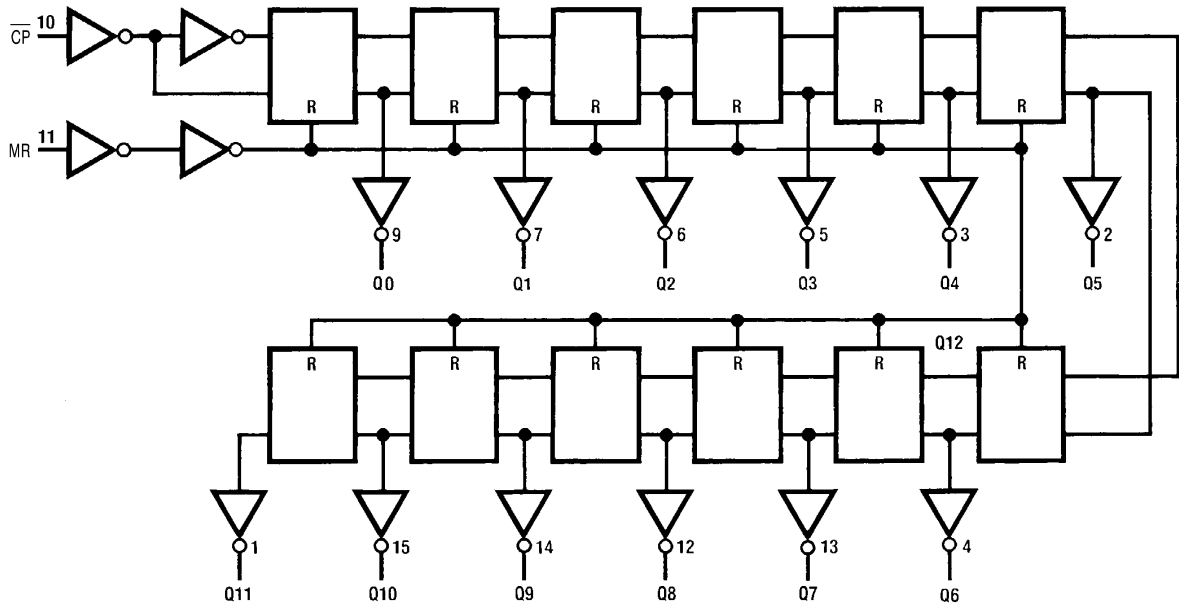

Timing Diagram

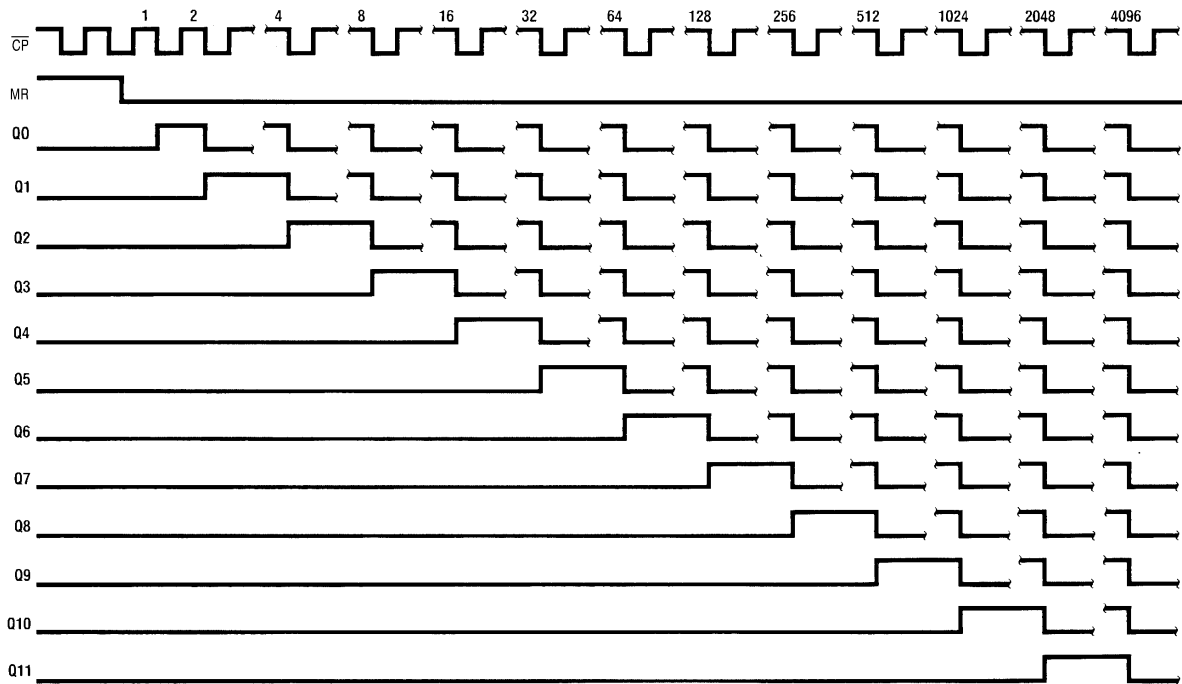

Absolute Maximum Ratings

Stresses exceeding the absolute maximum ratings may damage the device. The device may not function or be operable above the recommended operating conditions and stressing the parts to these levels is not recommended. In addition, extended exposure to stresses above the recommended operating conditions may affect device reliability. The absolute maximum ratings are stress ratings only.

Symbol	Parameter	Rating
V _{CC}	Supply Voltage	-0.5V to +7.0V
V _{IN}	DC Input Voltage	-0.5V to +7.0V
V _{OUT}	DC Output Voltage	-0.5V to V _{CC} + 0.5V
I _{IK}	Input Diode Current	-20mA
I _{OK}	Output Diode Current	±20mA
I _{OUT}	DC Output Current	±25mA
I _{CC}	DC V _{CC} / GND Current	±75mA
T _{STG}	Storage Temperature	-65°C to +150°C
T _L	Lead Temperature (Soldering, 10 seconds)	260°C

Recommended Operating Conditions⁽¹⁾

The Recommended Operating Conditions table defines the conditions for actual device operation. Recommended operating conditions are specified to ensure optimal performance to the datasheet specifications. Fairchild does not recommend exceeding them or designing to absolute maximum ratings.

Symbol	Parameter	Rating
V _{CC}	Supply Voltage	2.0V to +5.5V
V _{IN}	Input Voltage	0V to +5.5V
V _{OUT}	Output Voltage	0V to V _{CC}
T _{OPR}	Operating Temperature	-40°C to +85°C
t _r , t _f	Input Rise and Fall Time V _{CC} = 3.3V ±0.3V V _{CC} = 5.0V ±0.5V	0 ~ 100ns/V 0 ~ 20ns/V

Note:

1. Unused inputs must be held HIGH or LOW. They may not float.

DC Electrical Characteristics

Symbol	Parameter	V _{CC} (V)	Conditions		T _A = 25°C			T _A = -40°C to +85°C		Units	
					Min.	Typ.	Max.	Min.	Max.		
V _{IH}	HIGH Level Input Voltage	2.0			1.50			1.50		V	
		3.0 – 5.5			0.7 × V _{CC}			0.7 × V _{CC}			
V _{IL}	LOW Level Input Voltage	2.0					0.50	0.50	V		
		3.0 – 5.5					0.3 × V _{CC}	0.3 × V _{CC}			
V _{OH}	HIGH Level Output Voltage	2.0	V _{IN} = V _{IH} or V _{IL}	I _{OH} = -50μA	1.9	2.0		1.9		V	
		3.0			2.9	3.0		2.9			
		4.5			4.4	4.5		4.4			
		3.0				2.58			2.48		
		4.5				3.94			3.80		
V _{OL}	LOW Level Output Voltage	2.0	V _{IN} = V _{IH} or V _{IL}	I _{OL} = 50μA		0.0	0.1		0.1	V	
		3.0				0.0	0.1		0.1		
		4.5				0.0	0.1		0.1		
		3.0					0.36		0.44		
		4.5					0.36		0.44		
I _{IN}	Input Leakage Current	0 – 5.5	V _{IN} = 5.5V or GND				±0.1	±1.0	μA		
I _{CC}	Quiescent Supply Current	5.5	V _{IN} = V _{CC} or GND				4.0	40.0	μA		

AC Electrical Characteristics

Symbol	Parameter	V _{CC} (V)	Conditions	T _A = +25°C			T _A = -40°C to +85°C		Units	
				Min.	Typ.	Max.	Min.	Max.		
t _{PLH} , t _{PHL}	Propagation Delay Time to Q ₁	3.3 ± 0.3	C _L = 15pF		7.5	11.9	1.0	14.0	ns	
			C _L = 50pF		10.0	15.4	1.0	17.5		
		5.0 ± 0.5	C _L = 15pF		4.8	7.3	1.0	8.5	ns	
			C _L = 50pF		6.3	9.3	1.0	10.5		
t _{PLH} , t _{PHL}	Propagation Delay Time between Stages from Q _n to Q _{n+1}	3.3 ± 0.3	C _L = 15pF						ns	
			C _L = 50pF		2.4	4.4	1.0	5.0		
		5.0 ± 0.5	C _L = 15pF							ns
			C _L = 50pF		1.6	3.1	1.0	3.5		
t _{PHL}	Propagation Delay Time MR-Q _n	3.3 ± 0.3	C _L = 15pF		8.3	12.8	1.0	15.0	ns	
			C _L = 50pF		10.8	16.3	1.0	18.5		
		5.0 ± 0.5	C _L = 15pF		5.6	8.6	1.0	10.0	ns	
			C _L = 50pF		7.1	10.6	1.0	12.0		
f _{MAX}	Maximum Clock Frequency	3.3 ± 0.3	C _L = 15pF	90	140		75		MHz	
			C _L = 50pF	55	80		50			
		5.0 ± 0.5	C _L = 15pF	150	210		125		MHz	
			C _L = 50pF	95	125		80			
C _{IN}	Input Capacitance		V _{CC} = Open		4	10		10	pF	
C _{PD}	Power Dissipation Capacitance		(2)		21				pF	

Note:

2. C_{PD} is defined as the value of the internal equivalent capacitance which is calculated from the operating current consumption without load. Average operating current can be obtained by the equation:

$$I_{CC} (Opr.) = C_{PD} \cdot V_{CC} \cdot f_N + I_{CC}$$

AC Operating Requirements

Symbol	Parameter	V _{CC} (V)	T _A = 25°C		T _A = -40°C to +85°C		Units
			Typ.	Guaranteed Minimum			
t _{w(L)} , t _{w(H)}	Minimum Pulse Width (\overline{CP})	3.3 ± 0.3		5.0	5.0	ns	
		5.0 ± 0.5		5.0	5.0		
t _{w(L)}	Minimum Pulse Width (MR)	3.3 ± 0.3		5.0	5.0	ns	
		5.0 ± 0.5		5.0	5.0		
t _{REC}	Minimum Removal Time (MR)	3.3 ± 0.3		5.0	5.0	ns	
		5.0 ± 0.5		5.0	5.0		

Physical Dimensions

Dimensions are in millimeters unless otherwise noted.

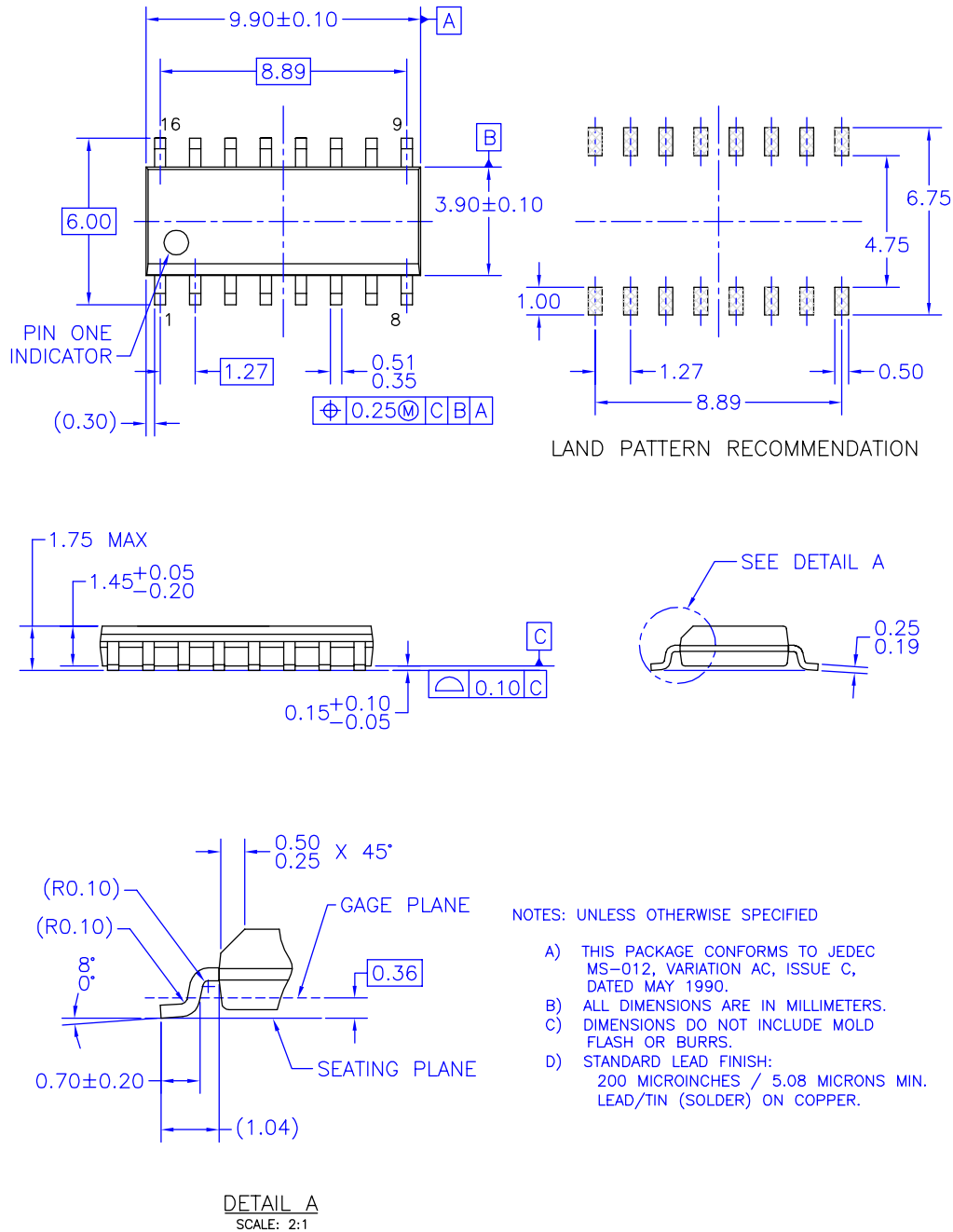

M16AREVK

Figure 1. 16-Lead Small Outline Integrated Circuit (SOIC), JEDEC MS-012, 0.150" Narrow Package Number M16A

Physical Dimensions (Continued)

Dimensions are in millimeters unless otherwise noted.

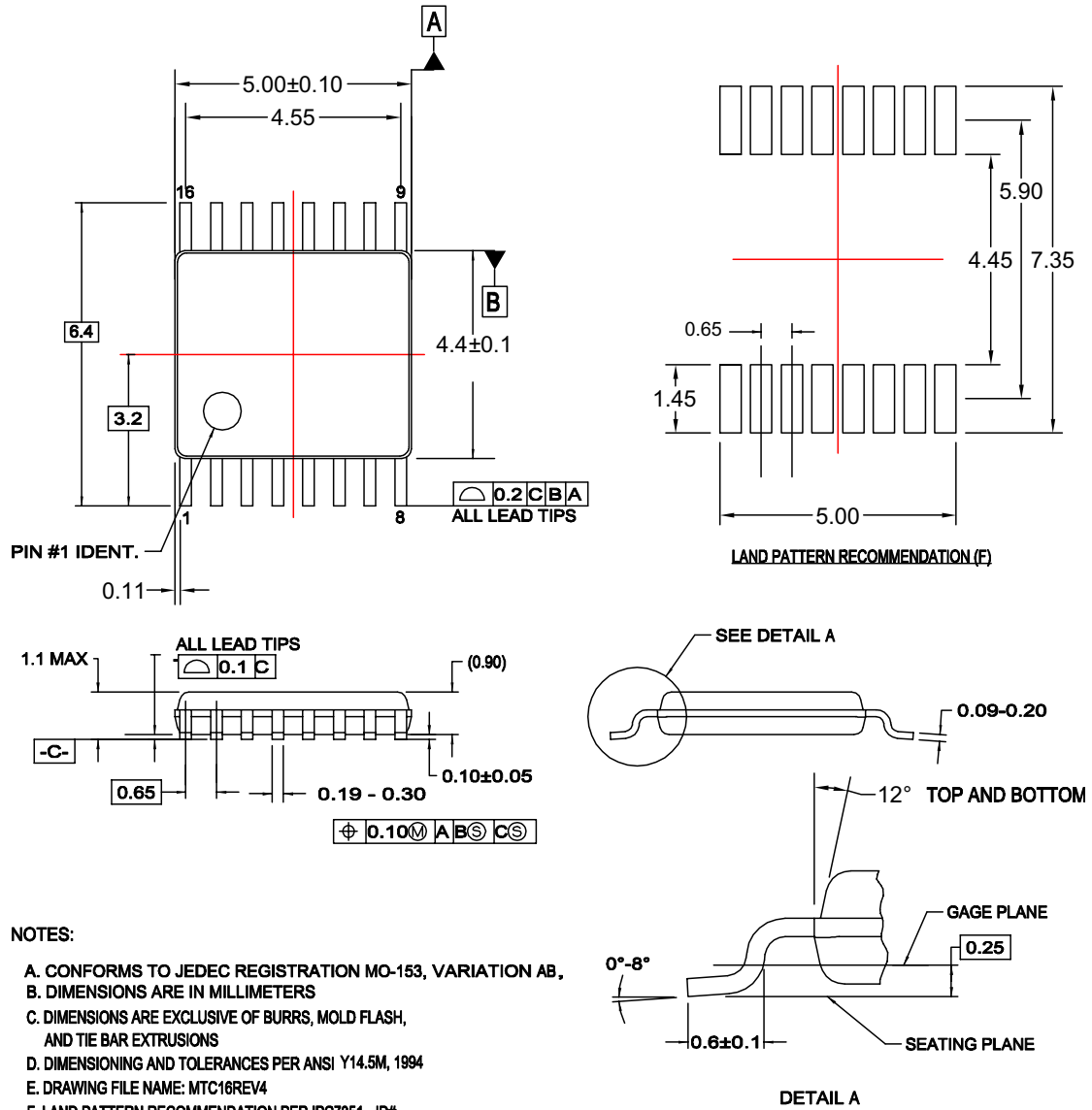

NOTES:

- A. CONFORMS TO JEDEC REGISTRATION MO-153, VARIATION AB,
- B. DIMENSIONS ARE IN MILLIMETERS
- C. DIMENSIONS ARE EXCLUSIVE OF BURRS, MOLD FLASH, AND TIE BAR EXTRUSIONS
- D. DIMENSIONING AND TOLERANCES PER ANSI Y14.5M, 1994
- E. DRAWING FILE NAME: MTC16REV4
- F. LAND PATTERN RECOMMENDATION PER IPC7351 - ID# TSOP65P640X110-16N

MTC16rev4

Figure 2. 16-Lead Thin Shrink Small Outline Package (TSSOP), JEDEC MO-153, 4.4mm Wide Package Number MTC16



TRADEMARKS

The following are registered and unregistered trademarks Fairchild Semiconductor owns or is authorized to use and is not intended to be an exhaustive list of all such trademarks.

ACEx [®]	HiSeC [™]	Power-SPM [™]	TinyBuck [™]
Across the board. Around the world. [™]	<i>i-Lo</i> [™]	PowerTrench [®]	TinyLogic [®]
ActiveArray [™]	ImpliedDisconnect [™]	Programmable Active Droop [™]	TINYOPTO [™]
Bottomless [™]	IntelliMAX [™]	QFET [®]	TinyPower [™]
Build it Now [™]	ISOPLANAR [™]	QS [™]	TinyWire [™]
CoolFET [™]	MICROCOUPLER [™]	QT Optoelectronics [™]	TruTranslation [™]
CorePLUS [™]	MicroPak [™]	Quiet Series [™]	μSerDes [™]
CROSSVOLT [™]	MICROWIRE [™]	RapidConfigure [™]	UHC [®]
CTL [™]	Motion-SPM [™]	RapidConnect [™]	UniFET [™]
Current Transfer Logic [™]	MSX [™]	ScalarPump [™]	VCX [™]
DOME [™]	MSXPro [™]	SMART START [™]	Wire [™]
E ² CMOS [™]	OCX [™]	SPM [®]	
EcoSPARK [®]	OCXPro [™]	STEALTH [™]	
EnSigna [™]	OPTOLOGIC [®]	SuperFET [™]	
FACT Quiet Series [™]	OPTOPLANAR [®]	SuperSOT [™] -3	
FACT [®]	PACMAN [™]	SuperSOT [™] -6	
FAST [®]	PDP-SPM [™]	SuperSOT [™] -8	
FASTr [™]	POP [™]	SyncFET [™]	
FPS [™]	Power220 [®]	TCM [™]	
FRFET [®]	Power247 [®]	The Power Franchise [®]	
GlobalOptoisolator [™]	PowerEdge [™]	 [™]	
GTO [™]	PowerSaver [™]	TinyBoost [™]	

DISCLAIMER

FAIRCHILD SEMICONDUCTOR RESERVES THE RIGHT TO MAKE CHANGES WITHOUT FURTHER NOTICE TO ANY PRODUCTS HEREIN TO IMPROVE RELIABILITY, FUNCTION, OR DESIGN. FAIRCHILD DOES NOT ASSUME ANY LIABILITY ARISING OUT OF THE APPLICATION OR USE OF ANY PRODUCT OR CIRCUIT DESCRIBED HEREIN; NEITHER DOES IT CONVEY ANY LICENSE UNDER ITS PATENT RIGHTS, NOR THE RIGHTS OF OTHERS. THESE SPECIFICATIONS DO NOT EXPAND THE TERMS OF FAIRCHILD'S WORLDWIDE TERMS AND CONDITIONS, SPECIFICALLY THE WARRANTY THEREIN, WHICH COVERS THESE PRODUCTS.

LIFE SUPPORT POLICY

FAIRCHILD'S PRODUCTS ARE NOT AUTHORIZED FOR USE AS CRITICAL COMPONENTS IN LIFE SUPPORT DEVICES OR SYSTEMS WITHOUT THE EXPRESS WRITTEN APPROVAL OF FAIRCHILD SEMICONDUCTOR CORPORATION.

As used herein:

1. Life support devices or systems are devices or systems which, (a) are intended for surgical implant into the body or (b) support or sustain life, and (c) whose failure to perform when properly used in accordance with instructions for use provided in the labeling, can be reasonably expected to result in a significant injury of the user.
2. A critical component in any component of a life support, device, or system whose failure to perform can be reasonably expected to cause the failure of the life support device or system, or to affect its safety or effectiveness.

PRODUCT STATUS DEFINITIONS

Definition of Terms

Datasheet Identification	Product Status	Definition
Advance Information	Formative or In Design	This datasheet contains the design specifications for product development. Specifications may change in any manner without notice.
Preliminary	First Production	This datasheet contains preliminary data; supplementary data will be published at a later date. Fairchild Semiconductor reserves the right to make changes at any time without notice to improve design.
No Identification Needed	Full Production	This datasheet contains final specifications. Fairchild Semiconductor reserves the right to make changes at any time without notice to improve design.
Obsolete	Not In Production	This datasheet contains specifications on a product that has been discontinued by Fairchild Semiconductor. The datasheet is printed for reference information only.

Rev. I27