

Excellent Integrated System Limited

Stocking Distributor

Click to view price, real time Inventory, Delivery & Lifecycle Information:

[Fairchild Semiconductor](#)

[BC182](#)

For any questions, you can email us directly:

sales@integrated-circuit.com

FAIRCHILD
SEMICONDUCTOR®

BC182

NPN General Purpose Amplifier

- This device is designed for general purpose amplifier application at collector currents to 100mA.
- Sourced from process 10.

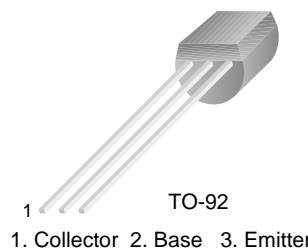

Absolute Maximum Ratings $T_C=25^\circ\text{C}$ unless otherwise noted

Symbol	Parameter	Value	Units
V_{CEO}	Collector-Emitter Voltage	50	V
V_{CBO}	Collector-Base Voltage	60	V
V_{EBO}	Emitter-Base Voltage	6	V
I_C	Collector Current - Continuous	100	mA
T_J, T_{STG}	Storage Junction Temperature Range	- 55 ~ 150	$^\circ\text{C}$

Electrical Characteristics $T_C=25^\circ\text{C}$ unless otherwise noted

Symbol	Parameter	Test Condition	Min.	Typ.	Max.	Units
Off Characteristics						
$V_{(BR)CEO}$	Collector-Emitter Breakdown Voltage	$I_C = 2\text{mA}, I_B = 0$	50			V
$V_{(BR)CBO}$	Collector-Base Breakdown Voltage	$I_C = 10\mu\text{A}, I_E = 0$	60			V
$V_{(BR)EBO}$	Emitter-Base Breakdown Voltage	$I_E = 10\mu\text{A}, I_C = 0$	6			V
I_{CBO}	Collector Cut-off Current	$V_{CB} = 50\text{V}, V_{BE} = 0$			15	nA
I_{EBO}	Emitter-Base Leakage Current	$V_{EB} = 4\text{V}, I_E = 0$			15	nA
On Characteristics						
h_{FE}	DC Current Gain	$V_{CE} = 5\text{V}, I_C = 10\mu\text{A}$ $V_{CE} = 5\text{V}, I_C = 2\text{mA}$ $V_{CE} = 5\text{V}, I_C = 100\text{mA}$	40 120 80		500	
$V_{CE(sat)}$	Collector-Emitter Saturation Voltage	$I_C = 10\text{mA}, I_B = 0.5\text{mA}$ $I_C = 100\text{mA}, I_B = 5\text{mA}$			0.25 0.6	V
$V_{BE(sat)}$	Base-Emitter Saturation Voltage	$I_C = 100\text{mA}, I_B = 5\text{mA}$			1.2	V
$V_{BE(on)}$	Base-Emitter On Voltage	$V_{CE} = 5\text{V}, I_C = 2\text{mA}$	0.55		0.7	V
Dynamic Characteristics						
f_T	Current Gain Bandwidth Product	$V_{CE} = 5\text{V}, I_C = 10\text{mA}, f = 100\text{MHz}$	150			MHz
C_{ob}	Output Capacitance	$V_{CE} = 10\text{V}, I_C = 0, f = 1\text{MHz}$			5	pF
h_{fe}	Small Signal Current Gain	$V_{CE} = 5\text{V}, I_C = 2\text{mA}, f = 1\text{KHz}$	125		500	
NF	Noise Figure	$V_{CE} = 5\text{V}, I_C = 0.2\text{mA}$ $R_S = 2\text{K}\Omega, f = 1\text{KHz}$			10	dB

Thermal Characteristics $T_A=25^{\circ}\text{C}$ unless otherwise noted

Symbol	Parameter	Max.	Units
P _D	Total Device Dissipation @ $T_A=25^{\circ}\text{C}$	350	mW
	Derate above 25°C	2.8	mW/°C
R _{θJA}	Thermal Resistance, Junction to Ambient	357	mW/°C
R _{θJC}	Thermal Resistance, Junction to Case	125	°C/W

Package Dimensions

TO-92

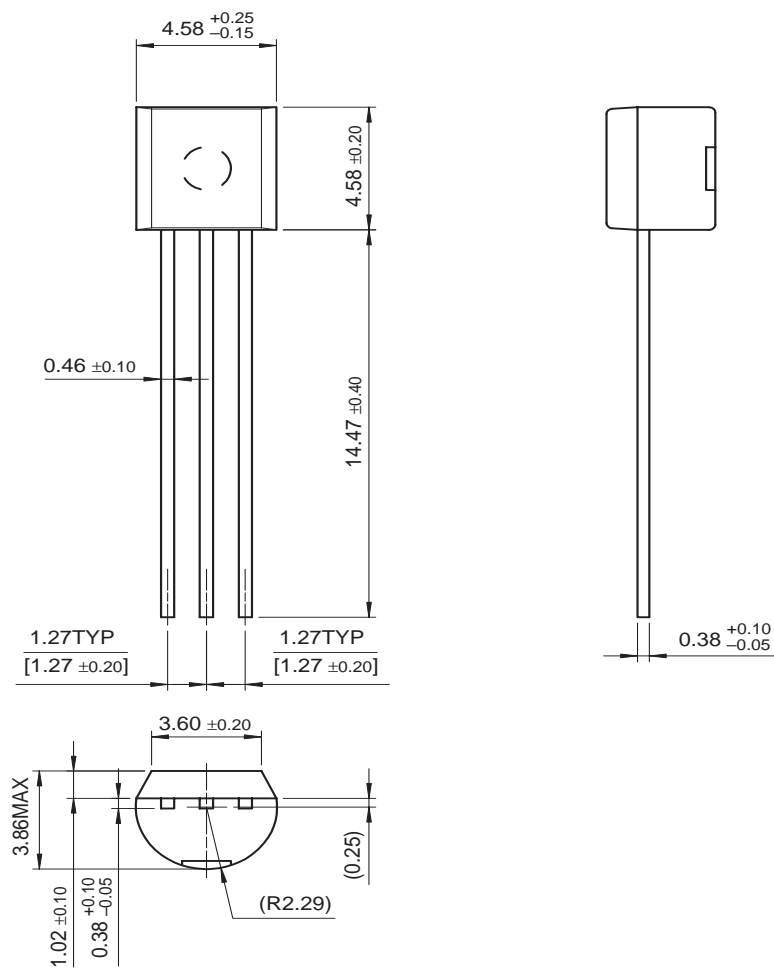

Dimensions in Millimeters

TRADEMARKS

The following are registered and unregistered trademarks Fairchild Semiconductor owns or is authorized to use and is not intended to be an exhaustive list of all such trademarks.

ACEx™	FAST®	ISOPLANAR™	PowerSaver™	SuperSOT™-8
ActiveArray™	FASTr™	LittleFET™	PowerTrench®	SyncFET™
Bottomless™	FPST™	MICROCOUPLER™	QFET®	TinyLogic®
Build it Now™	FRFET™	MicroFET™	QS™	TINYOPTO™
CoolFET™	GlobalOptoisolator™	MicroPak™	QT Optoelectronics™	TruTranslation™
CROSSVOLT™	GTO™	MICROWIRE™	Quiet Series™	UHC™
DOMET™	HiSeC™	MSX™	RapidConfigure™	UltraFET®
EcoSPARK™	I ² C™	MSXPro™	RapidConnect™	UniFET™
E ² CMOS™	i-Lo™	OCX™	µSerDes™	VCX™
EnSigna™	ImpliedDisconnect™	OCXPro™	SILENT SWITCHER®	Wire™
FACT™	IntelliMAX™	OPTOLOGIC®	SMART START™	
FACT Quiet Series™		OPTOPLANAR™	SPM™	
Across the board. Around the world.™		PACMAN™	Stealth™	
The Power Franchise®		POP™	SuperFET™	
Programmable Active Droop™		Power247™	SuperSOT™-3	
		PowerEdge™	SuperSOT™-6	

DISCLAIMER

FAIRCHILD SEMICONDUCTOR RESERVES THE RIGHT TO MAKE CHANGES WITHOUT FURTHER NOTICE TO ANY PRODUCTS HEREIN TO IMPROVE RELIABILITY, FUNCTION OR DESIGN. FAIRCHILD DOES NOT ASSUME ANY LIABILITY ARISING OUT OF THE APPLICATION OR USE OF ANY PRODUCT OR CIRCUIT DESCRIBED HEREIN; NEITHER DOES IT CONVEY ANY LICENSE UNDER ITS PATENT RIGHTS, NOR THE RIGHTS OF OTHERS.

LIFE SUPPORT POLICY

FAIRCHILD'S PRODUCTS ARE NOT AUTHORIZED FOR USE AS CRITICAL COMPONENTS IN LIFE SUPPORT DEVICES OR SYSTEMS WITHOUT THE EXPRESS WRITTEN APPROVAL OF FAIRCHILD SEMICONDUCTOR CORPORATION. As used herein:

1. Life support devices or systems are devices or systems which, (a) are intended for surgical implant into the body, or (b) support or sustain life, or (c) whose failure to perform when properly used in accordance with instructions for use provided in the labeling, can be reasonably expected to result in significant injury to the user.
2. A critical component is any component of a life support device or system whose failure to perform can be reasonably expected to cause the failure of the life support device or system, or to affect its safety or effectiveness.

PRODUCT STATUS DEFINITIONS

Definition of Terms

Datasheet Identification	Product Status	Definition
Advance Information	Formative or In Design	This datasheet contains the design specifications for product development. Specifications may change in any manner without notice.
Preliminary	First Production	This datasheet contains preliminary data, and supplementary data will be published at a later date. Fairchild Semiconductor reserves the right to make changes at any time without notice in order to improve design.
No Identification Needed	Full Production	This datasheet contains final specifications. Fairchild Semiconductor reserves the right to make changes at any time without notice in order to improve design.
Obsolete	Not In Production	This datasheet contains specifications on a product that has been discontinued by Fairchild semiconductor. The datasheet is printed for reference information only.